



**COMMONWEALTH OF PENNSYLVANIA
DEPARTMENT OF ENVIRONMENTAL PROTECTION
AIR QUALITY PROGRAM**

STATE ONLY NATURAL MINOR OPERATING PERMIT

Issue Date: April 18, 2024

Effective Date: April 18, 2024

Expiration Date: April 17, 2029

In accordance with the provisions of the Air Pollution Control Act, the Act of January 8, 1960, P.L. 2119, as amended, and 25 Pa. Code Chapter 127, the Owner, [and Operator if noted] (hereinafter referred to as permittee) identified below is authorized by the Department of Environmental Protection (Department) to operate the air emission source(s) more fully described in this permit. This Facility is subject to all terms and conditions specified in this permit. Nothing in this permit relieves the permittee from its obligations to comply with all applicable Federal, State and Local laws and regulations.

The regulatory or statutory authority for each permit condition is set forth in brackets. All terms and conditions in this permit are federally enforceable unless otherwise designated.

State Only Permit No: 41-00020

Natural Minor

Federal Tax Id - Plant Code: 24-0630030-1

Owner Information

Name: KEYSTONE FILLER & MFG CO

Mailing Address: 214 RAILROAD ST
MUNCY, PA 17756-1422

Plant Information

Plant: KEYSTONE FILLER & MFG/MUNCY COAL PREP PLT

Location: 41 Lycoming County 41935 Muncy Creek Township

SIC Code: 3295 Manufacturing - Minerals, Ground Or Treated

Responsible Official

Name: DAVID W PFLEEGOR

Title: CEO

Phone: (570) 546 - 3148

Email: Dave@keystonefiller.com

Permit Contact Person

Name: CHRIS CHRONISTER

Title: GEN MGR

Phone: (570) 546 - 3148

Email: Chris@keystonefiller.com

[Signature] _____

MUHAMMAD Q. ZAMAN, ENVIRONMENTAL PROGRAM MANAGER, NORTHCENTRAL REGION



SECTION A. Table of Contents

Section A. Facility/Source Identification

Table of Contents
Site Inventory List

Section B. General State Only Requirements

- #001 Definitions.
- #002 Operating Permit Duration.
- #003 Permit Renewal.
- #004 Operating Permit Fees under Subchapter I.
- #005 Transfer of Operating Permits.
- #006 Inspection and Entry.
- #007 Compliance Requirements.
- #008 Need to Halt or Reduce Activity Not a Defense.
- #009 Duty to Provide Information.
- #010 Revising an Operating Permit for Cause.
- #011 Operating Permit Modifications
- #012 Severability Clause.
- #013 De Minimis Emission Increases.
- #014 Operational Flexibility.
- #015 Reactivation
- #016 Health Risk-based Emission Standards and Operating Practice Requirements.
- #017 Circumvention.
- #018 Reporting Requirements.
- #019 Sampling, Testing and Monitoring Procedures.
- #020 Recordkeeping.
- #021 Property Rights.
- #022 Alternative Operating Scenarios.
- #023 Reporting
- #024 Report Format

Section C. Site Level State Only Requirements

- C-I: Restrictions
- C-II: Testing Requirements
- C-III: Monitoring Requirements
- C-IV: Recordkeeping Requirements
- C-V: Reporting Requirements
- C-VI: Work Practice Standards
- C-VII: Additional Requirements
- C-VIII: Compliance Certification
- C-IX: Compliance Schedule

Section D. Source Level State Only Requirements

- D-I: Restrictions
- D-II: Testing Requirements
- D-III: Monitoring Requirements
- D-IV: Recordkeeping Requirements
- D-V: Reporting Requirements
- D-VI: Work Practice Standards
- D-VII: Additional Requirements

Note: These same sub-sections are repeated for each source!

Section E. Source Group Restrictions

- E-I: Restrictions



SECTION A. Table of Contents

- E-II: Testing Requirements
- E-III: Monitoring Requirements
- E-IV: Recordkeeping Requirements
- E-V: Reporting Requirements
- E-VI: Work Practice Standards
- E-VII: Additional Requirements

Section F. Alternative Operating Scenario(s)

- F-I: Restrictions
- F-II: Testing Requirements
- F-III: Monitoring Requirements
- F-IV: Recordkeeping Requirements
- F-V: Reporting Requirements
- F-VI: Work Practice Standards
- F-VII: Additional Requirements

Section G. Emission Restriction Summary

Section H. Miscellaneous

**SECTION A. Site Inventory List**

Source ID	Source Name	Capacity/Throughput	Fuel/Material
031	NATURAL GAS-FIRED COMBUSTION UNIT		
P301	#3 DRYER		
P302	#1 MILL		
P303	ACM MILL		
P304	#2 MILL		
P305	#4 DRYER		
P306	#5 DRYER		
P307	MATERIAL STORAGE OPERATION		
P308	CEDAR RAPIDS PORTABLE CRUSHING PLANT		
P309	KOLMAN PORTABLE SCREENING PLANT		
P310	TESAB PORTABLE CRUSHING PLANT		
P311	EXTEC PORTABLE SCREENING PLANT		
P312	PARTS DEGREASER		
P313	PORTABLE WELDER WITH GASOLINE-FIRED GENERATOR		
C301	MIKROPUL MODEL 81S-10-20		
C302A	GRIFFIN MODEL JA-140-SA		
C302B	MIKROPUL MODEL 81S-10-20		
C303	MIKROPUL MODEL 10S-10-100		
C304A	GRIFFIN MODEL JA-140-SA		
C304B	MIKROPUL MODEL 9S-10-20		
C304C	GRIFFIN MODEL JA-200-SA		
C305	MIKROPUL MODEL 400S-TRH-10		
C305A	MAC RECEIVER		
C306	MIKROPUL MODEL 400S-TRH-10		
C307A	FLEX KLEEN MODEL 100-WRT-160		
C307B	#1 SILO DYNAMIC AIR MODEL 400-343 CARTRIDGE COLLECTOR		
C307C	#4 SILO DYNAMIC AIR MODEL 400-343 CARTRIDGE COLLECTOR		
C307D	#7 SILO DYNAMIC AIR MODEL 400-343 CARTRIDGE COLLECTOR		
C308	WATER SPRAY DUST SUPPRESSION SYSTEM		
C309	WATER SPRAY DUST SUPPRESSION SYSTEM		
C310	WATER SPRAY DUST SUPPRESSION SYSTEM		
C310A	CATALYZED CONVERTER/MUFFLER		
C311	WATER SPRAY DUST SUPPRESSION SYSTEM		
FM01	NATURAL GAS		
FM02	#2 FUEL OIL		
FM04	GASOLINE		
S031	STACK		
S301	STACK		
S302A	STACK		

**SECTION A. Site Inventory List**

Source ID	Source Name	Capacity/Throughput	Fuel/Material
S302B	STACK		
S303	STACK		
S304A	STACK		
S304B	STACK		
S304C	STACK		
S305	STACK		
S305A	STACK		
S306	STACK		
S307A	STACK		
S307B	STACK		
S307C	STACK		
S307D	STACK		
S310A	STACK		
S313	STACK		
Z308	FUGITIVE DUST		
Z309	FUGITIVE DUST		
Z310	FUGITIVE DUST		
Z311	FUGITIVE DUST		
Z312	FUGITIVE VOCS		

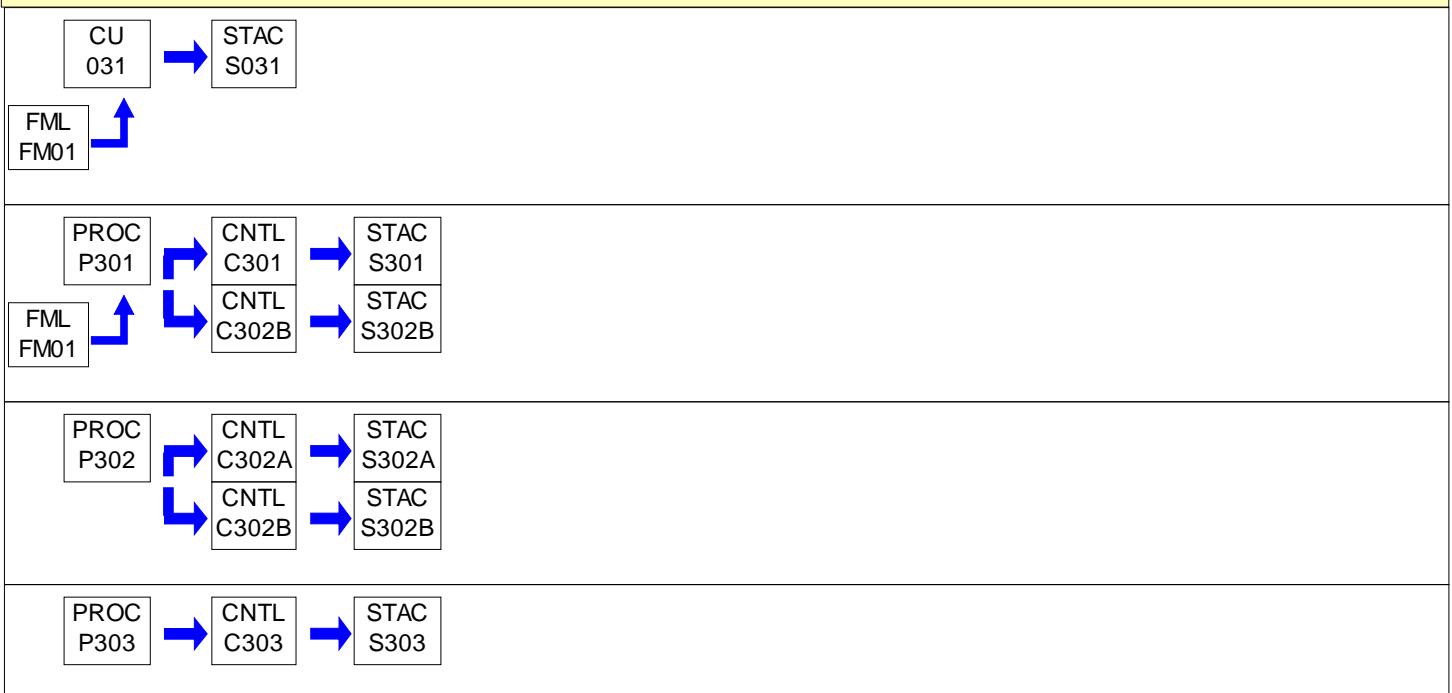
PERMIT MAPS



PERMIT MAPS

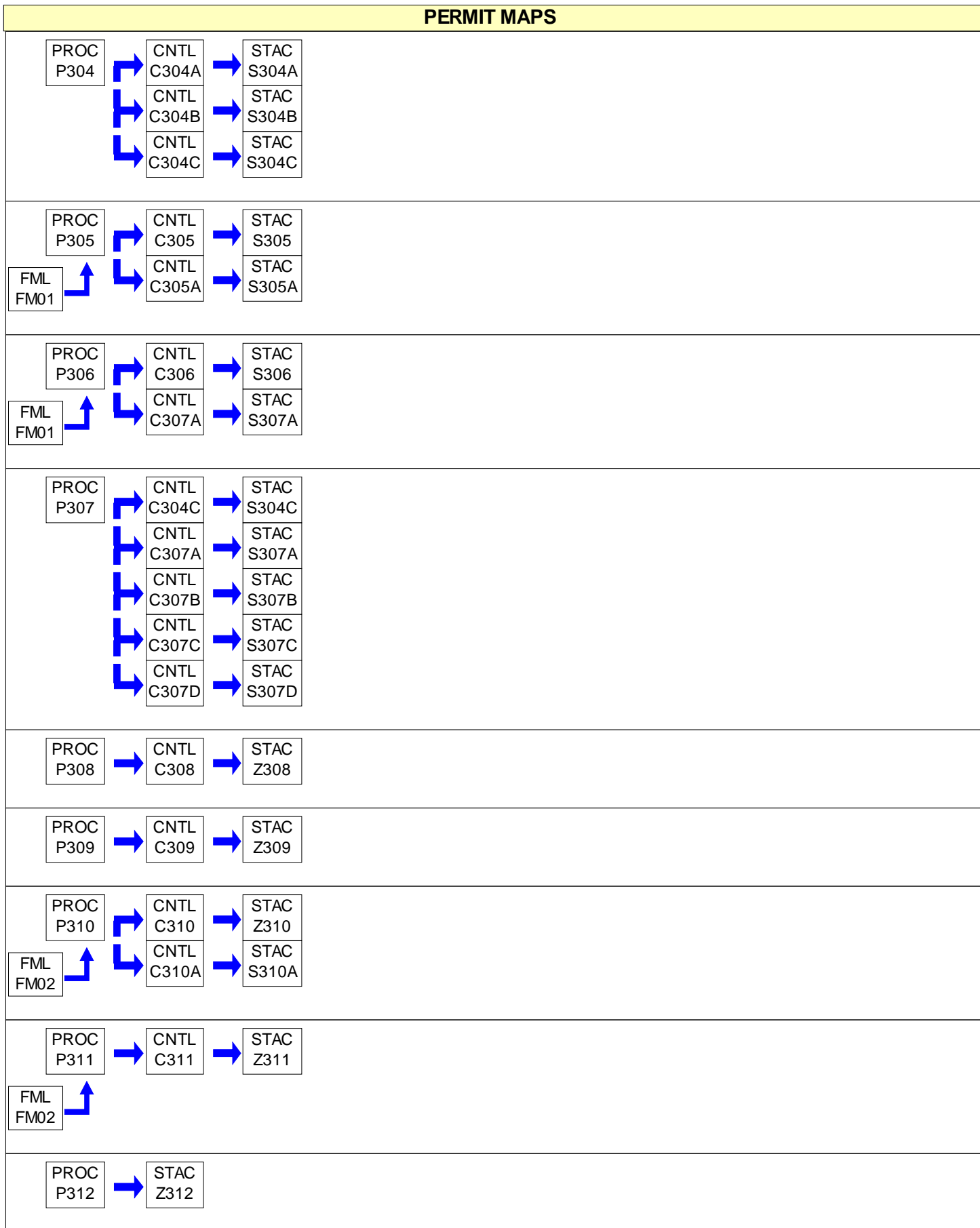



PERMIT MAPS

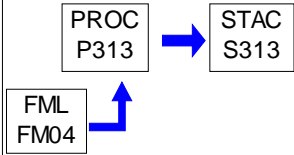

**SECTION B. General State Only Requirements****#001 [25 Pa. Code § 121.1]****Definitions.**

Words and terms that are not otherwise defined in this permit shall have the meanings set forth in Section 3 of the Air Pollution Control Act (35 P.S. § 4003) and in 25 Pa. Code § 121.1.

#002 [25 Pa. Code § 127.446]**Operating Permit Duration.**

- (a) This operating permit is issued for a fixed term of five (5) years and shall expire on the date specified on Page 1 of this permit.
- (b) The terms and conditions of the expired permit shall automatically continue pending issuance of a new operating permit, provided the permittee has submitted a timely and complete application and paid applicable fees required under 25 Pa. Code Chapter 127, Subchapter I and the Department is unable, through no fault of the permittee, to issue or deny a new permit before the expiration of the previous permit.

#003 [25 Pa. Code §§ 127.412, 127.413, 127.414, 127.446 & 127.703(b)]**Permit Renewal.**

- (a) The permittee shall submit a timely and complete application for renewal of the operating permit to the appropriate Regional Air Program Manager. The application for renewal of the operating permit shall be submitted at least six (6) months and not more than 18 months before the expiration date of this permit.
- (b) The application for permit renewal shall include the current permit number, a description of any permit revisions that occurred during the permit term, and any applicable requirements that were promulgated and not incorporated into the permit during the permit term. An application is complete if it contains sufficient information to begin processing the application, has the applicable sections completed and has been signed by a responsible official.
- (c) The permittee shall submit with the renewal application a fee for the processing of the application as specified in 25 Pa. Code § 127.703(b). The fees shall be made payable to "The Commonwealth of Pennsylvania Clean Air Fund" and submitted with the fee form to the respective regional office.
- (d) The renewal application shall also include submission of proof that the local municipality and county, in which the facility is located, have been notified in accordance with 25 Pa. Code § 127.413.
- (e) The application for renewal of the operating permit shall also include submission of supplemental compliance review forms in accordance with the requirements of 25 Pa. Code § 127.412(b) and § 127.412(j).
- (f) The permittee, upon becoming aware that any relevant facts were omitted or incorrect information was submitted in the permit application, shall promptly submit such supplementary facts or corrected information as necessary to address any requirements that become applicable to the source after the permittee submits a complete application, but prior to the date the Department takes action on the permit application.

#004 [25 Pa. Code § 127.703]**Operating Permit Fees under Subchapter I.**

- (a) The permittee shall pay the annual operating permit maintenance fee according to the following fee schedule in either paragraph (1) or (2) in accordance with 25 Pa. Code § 127.703(d) on or before December 31 of each year for the next calendar year.
- (1) For a synthetic minor facility, a fee equal to:
- (i) Four thousand dollars (\$4,000) for calendar years 2021—2025.
 - (ii) Five thousand dollars (\$5,000) for calendar years 2026—2030.
 - (iii) Six thousand three hundred dollars (\$6,300) for the calendar years beginning with 2031.

**SECTION B. General State Only Requirements**

(2) For a facility that is not a synthetic minor, a fee equal to:

- (i) Two thousand dollars (\$2,000) for calendar years 2021—2025.
- (ii) Two thousand five hundred dollars (\$2,500) for calendar years 2026—2030.
- (iii) Three thousand one hundred dollars (\$3,100) for the calendar years beginning with 2031.

(b) The applicable fees shall be made payable to "The Commonwealth of Pennsylvania Clean Air Fund" with the permit number clearly indicated and submitted to the respective regional office.

#005 [25 Pa. Code §§ 127.450 (a)(4) and 127.464]**Transfer of Operating Permits.**

(a) This operating permit may not be transferred to another person, except in cases of transfer-of-ownership that are documented and approved by the Department.

(b) In accordance with 25 Pa. Code § 127.450(a)(4), a change in ownership of the source shall be treated as an administrative amendment if the Department determines that no other change in the permit is required and a written agreement has been submitted to the Department identifying the specific date of the transfer of permit responsibility, coverage and liability between the current and the new permittee and a compliance review form has been submitted to, and the permit transfer has been approved by, the Department.

(c) This operating permit is valid only for those specific sources and the specific source locations described in this permit.

#006 [25 Pa. Code § 127.441 and 35 P.S. § 4008]**Inspection and Entry.**

(a) Upon presentation of credentials and other documents as may be required by law, the permittee shall allow the Department or authorized representatives of the Department to perform the following:

(1) Enter at reasonable times upon the permittee's premises where a source is located or emissions related activity is conducted, or where records are kept under the conditions of this permit;

(2) Have access to and copy, at reasonable times, any records that are kept under the conditions of this permit;

(3) Inspect at reasonable times, any facilities, equipment including monitoring and air pollution control equipment, practices, or operations regulated or required under this permit;

(4) Sample or monitor, at reasonable times, any substances or parameters, for the purpose of assuring compliance with the permit or applicable requirements as authorized by the Clean Air Act, the Air Pollution Control Act, or the regulations promulgated under the Acts.

(b) Pursuant to 35 P.S. § 4008, no person shall hinder, obstruct, prevent or interfere with the Department or its personnel in the performance of any duty authorized under the Air Pollution Control Act or regulations adopted thereunder including denying the Department access to a source at this facility. Refusal of entry or access may constitute grounds for permit revocation and assessment of criminal and/or civil penalties.

(c) Nothing in this permit condition shall limit the ability of the EPA to inspect or enter the premises of the permittee in accordance with Section 114 or other applicable provisions of the Clean Air Act.

#007 [25 Pa. Code §§ 127.441 & 127.444]**Compliance Requirements.**

(a) The permittee shall comply with the conditions of this operating permit. Noncompliance with this permit constitutes a violation of the Clean Air Act and the Air Pollution Control Act and is grounds for one or more of the following:

**SECTION B. General State Only Requirements**

- (1) Enforcement action
- (2) Permit termination, revocation and reissuance or modification
- (3) Denial of a permit renewal application

(b) A person may not cause or permit the operation of a source which is subject to 25 Pa. Code Article III unless the source(s) and air cleaning devices identified in the application for the plan approval and operating permit and the plan approval issued for the source is operated and maintained in accordance with specifications in the applications and the conditions in the plan approval and operating permit issued by the Department. A person may not cause or permit the operation of an air contamination source subject to 25 Pa. Code Chapter 127 in a manner inconsistent with good operating practices.

(c) For purposes of Sub-condition (b) of this permit condition, the specifications in applications for plan approvals and operating permits are the physical configurations and engineering design details which the Department determines are essential for the permittee's compliance with the applicable requirements in this State-Only permit. Nothing in this sub-condition shall be construed to create an independent affirmative duty upon the permittee to obtain a predetermination from the Department for physical configuration or engineering design detail changes made by the permittee.

#008 [25 Pa. Code § 127.441]**Need to Halt or Reduce Activity Not a Defense.**

It shall not be a defense for the permittee in an enforcement action that it was necessary to halt or reduce the permitted activity in order to maintain compliance with the conditions of this permit.

#009 [25 Pa. Code §§ 127.442(a) & 127.461]**Duty to Provide Information.**

(a) The permittee shall submit reports to the Department containing information the Department may prescribe relative to the operation and maintenance of each source at the facility.

(b) The permittee shall furnish to the Department, in writing, information that the Department may request to determine whether cause exists for modifying, revoking and reissuing, or terminating this permit, or to determine compliance with the permit. Upon request, the permittee shall also furnish to the Department copies of records that the permittee is required to maintain in accordance with this permit.

#010 [25 Pa. Code § 127.461]**Revising an Operating Permit for Cause.**

This operating permit may be terminated, modified, suspended or revoked and reissued if one or more of the following applies:

- (1) The permittee constructs or operates the source subject to the operating permit so that it is in violation of the Air Pollution Control Act, the Clean Air Act, the regulations thereunder, a plan approval, a permit or in a manner that causes air pollution.
- (2) The permittee fails to properly or adequately maintain or repair an air pollution control device or equipment attached to or otherwise made a part of the source.
- (3) The permittee has failed to submit a report required by the operating permit or an applicable regulation.
- (4) The EPA determines that the permit is not in compliance with the Clean Air Act or the regulations thereunder.

#011 [25 Pa. Code §§ 127.450, 127.462, 127.465 & 127.703]**Operating Permit Modifications**

(a) The permittee is authorized to make administrative amendments, minor operating permit modifications and significant operating permit modifications, under this permit, as outlined below:

**SECTION B. General State Only Requirements**

(b) Administrative Amendments. The permittee shall submit the application for administrative operating permit amendments (as defined in 25 Pa. Code § 127.450(a)), according to procedures specified in § 127.450 unless precluded by the Clean Air Act or its regulations.

(c) Minor Operating Permit Modifications. The permittee shall submit the application for minor operating permit modifications (as defined 25 Pa. Code § 121.1) in accordance with 25 Pa. Code § 127.462.

(d) Significant Operating Permit Modifications. The permittee shall submit the application for significant operating permit modifications in accordance with 25 Pa. Code § 127.465.

(e) The applicable fees shall be made payable to "The Commonwealth of Pennsylvania Clean Air Fund" with the permit number clearly indicated and submitted to the respective regional office.

#012 [25 Pa. Code § 127.441]**Severability Clause.**

The provisions of this permit are severable, and if any provision of this permit is determined by a court of competent jurisdiction to be invalid or unenforceable, such a determination will not affect the remaining provisions of this permit.

#013 [25 Pa. Code § 127.449]**De Minimis Emission Increases.**

(a) This permit authorizes de minimis emission increases in accordance with 25 Pa. Code § 127.449 so long as the permittee provides the Department with seven (7) days prior written notice before commencing any de minimis emissions increase. The written notice shall:

(1) Identify and describe the pollutants that will be emitted as a result of the de minimis emissions increase.

(2) Provide emission rates expressed in tons per year and in terms necessary to establish compliance consistent with any applicable requirement.

(b) The Department may disapprove or condition de minimis emission increases at any time.

(c) Except as provided below in (d), the permittee is authorized to make de minimis emission increases (expressed in tons per year) up to the following amounts without the need for a plan approval or prior issuance of a permit modification:

(1) Four tons of carbon monoxide from a single source during the term of the permit and 20 tons of carbon monoxide at the facility during the term of the permit.

(2) One ton of NO_x from a single source during the term of the permit and 5 tons of NO_x at the facility during the term of the permit.

(3) One and six-tenths tons of the oxides of sulfur from a single source during the term of the permit and 8.0 tons of oxides of sulfur at the facility during the term of the permit.

(4) Six-tenths of a ton of PM₁₀ from a single source during the term of the permit and 3.0 tons of PM₁₀ at the facility during the term of the permit. This shall include emissions of a pollutant regulated under Section 112 of the Clean Air Act unless precluded by the Clean Air Act, the regulations thereunder or 25 Pa. Code Article III.

(5) One ton of VOCs from a single source during the term of the permit and 5.0 tons of VOCs at the facility during the term of the permit. This shall include emissions of a pollutant regulated under Section 112 of the Clean Air Act unless precluded by the Clean Air Act, the regulations thereunder or 25 Pa. Code Article III.

(6) Other sources and classes of sources determined to be of minor significance by the Department.

(d) In accordance with § 127.14, the permittee is authorized to install the following minor sources without the need for a plan approval or permit modification:

**SECTION B. General State Only Requirements**

(1) Air conditioning or ventilation systems not designed to remove pollutants generated or released from other sources.

(2) Combustion units rated at 2,500,000 or less Btu per hour of heat input.

(3) Combustion units with a rated capacity of less than 10,000,000 Btu per hour heat input fueled by natural gas supplied by a public utility or by commercial fuel oils which are No. 2 or lighter, viscosity less than or equal to 5.82 c St, and which meet the sulfur content requirements of 25 Pa. Code §123.22 (relating to combustion units). For purposes of this permit, commercial fuel oil shall be virgin oil which has no reprocessed, recycled or waste material added.

(4) Space heaters which heat by direct heat transfer.

(5) Laboratory equipment used exclusively for chemical or physical analysis.

(6) Other sources and classes of sources determined to be of minor significance by the Department.

(e) This permit does not authorize de minimis emission increases if the emissions increase would cause one or more of the following:

(1) Increase the emissions of a pollutant regulated under Section 112 of the Clean Air Act except as authorized in Subparagraphs (c)(4) and (5) of this permit condition.

(2) Subject the facility to the prevention of significant deterioration requirements in 25 Pa. Code Chapter 127, Subchapter D and/or the new source review requirements in Subchapter E.

(3) Violate any applicable requirement of this permit, the Air Pollution Control Act, the Clean Air Act, or the regulations promulgated under either of the acts.

(f) Emissions authorized under this permit condition shall be included in the monitoring, recordkeeping and reporting requirements of this permit.

(g) Except for de minimis emission increases, installation of minor sources made pursuant to this permit condition and Plan Approval Exemptions under 25 Pa. Code § 127.14 (relating to exemptions), the permittee is prohibited from making changes or engaging in activities that are not specifically authorized under this permit without first applying for a plan approval. In accordance with § 127.14(b), a plan approval is not required for the construction, modification, reactivation, or installation of the sources creating the de minimis emissions increase.

(h) The permittee may not meet de minimis emission threshold levels by offsetting emission increases or decreases at the same source.

#014 [25 Pa. Code § 127.3]**Operational Flexibility.**

The permittee is authorized to make changes within the facility in accordance with the regulatory provisions outlined in 25 Pa. Code § 127.3 (relating to operational flexibility) to implement the operational flexibility requirements provisions authorized under Section 6.1(i) of the Air Pollution Control Act and the operational flexibility terms and conditions of this permit. The provisions in 25 Pa. Code Chapter 127 which implement the operational flexibility requirements include the following:

(1) Section 127.14 (relating to exemptions)

(2) Section 127.447 (relating to alternative operating scenarios)

(3) Section 127.448 (relating to emissions trading at facilities with Federally enforceable emissions caps)

(4) Section 127.449 (relating to de minimis emission increases)

(5) Section 127.450 (relating to administrative operating permit amendments)

**SECTION B. General State Only Requirements**

(6) Section 127.462 (relating to minor operating permit modifications)

(7) Subchapter H (relating to general plan approvals and general operating permits)

#015 [25 Pa. Code § 127.11]**Reactivation**

(a) The permittee may not reactivate a source that has been out of operation or production for at least one year unless the reactivation is conducted in accordance with a plan approval granted by the Department or in accordance with reactivation and maintenance plans developed and approved by the Department in accordance with 25 Pa. Code § 127.11a(a).

(b) A source which has been out of operation or production for more than five (5) years but less than 10 years may be reactivated and will not be considered a new source if the permittee satisfies the conditions specified in 25 Pa. Code § 127.11a(b).

#016 [25 Pa. Code § 127.36]**Health Risk-based Emission Standards and Operating Practice Requirements.**

(a) When needed to protect public health, welfare and the environment from emissions of hazardous air pollutants from new and existing sources, the permittee shall comply with the health risk-based emission standards or operating practice requirements imposed by the Department, except as precluded by §§ 6.6(d)(2) and (3) of the Air Pollution Control Act [35 P.S. § 4006.6(d)(2) and (3)].

(b) A person challenging a performance or emission standard established by the Department has the burden to demonstrate that performance or emission standard does not meet the requirements of Section 112 of the Clean Air Act.

#017 [25 Pa. Code § 121.9]**Circumvention.**

No person may permit the use of a device, stack height which exceeds good engineering practice stack height, dispersion technique or other technique which, without resulting in reduction of the total amount of air contaminants emitted, conceals or dilutes an emission of air contaminants which would otherwise be in violation of 25 Pa. Code Article III, except that with prior approval of the Department, the device or technique may be used for control of malodors.

#018 [25 Pa. Code §§ 127.402(d) & 127.442]**Reporting Requirements.**

(a) The permittee shall comply with the applicable reporting requirements of the Clean Air Act, the regulations thereunder, the Air Pollution Control Act and 25 Pa. Code Article III including Chapters 127, 135 and 139.

(b) The permittee shall submit reports to the Department containing information the Department may prescribe relative to the operation and maintenance of any air contamination source.

(c) Reports, test data, monitoring data, notifications and requests for renewal of the permit shall be submitted to the:

Regional Air Program Manager
PA Department of Environmental Protection
(At the address given in the permit transmittal letter, or otherwise notified)

(d) Any records or information including applications, forms, or reports submitted pursuant to this permit condition shall contain a certification by a responsible official as to truth, accuracy and completeness. The certifications submitted under this permit shall require a responsible official of the facility to certify that based on information and belief formed after reasonable inquiry, the statements and information in the documents are true, accurate and complete.

(e) Any records, reports or information submitted to the Department shall be available to the public except for such

**SECTION B. General State Only Requirements**

records, reports or information which meet the confidentiality requirements of § 4013.2 of the Air Pollution Control Act and §§ 112(d) and 114(c) of the Clean Air Act. The permittee may not request a claim of confidentiality for any emissions data generated for the facility.

#019 [25 Pa. Code §§ 127.441(c) & 135.5]**Sampling, Testing and Monitoring Procedures.**

(a) The permittee shall comply with the monitoring, recordkeeping or reporting requirements of 25 Pa. Code Chapter 139 and the other applicable requirements of 25 Pa. Code Article III and additional requirements related to monitoring, reporting and recordkeeping required by the Clean Air Act and the regulations thereunder including the Compliance Assurance Monitoring requirements of 40 CFR Part 64, where applicable.

(b) Unless alternative methodology is required by the Clean Air Act and regulations adopted thereunder, sampling, testing and monitoring required by or used by the permittee to demonstrate compliance with any applicable regulation or permit condition shall be conducted in accordance with the requirements of 25 Pa. Code Chapter 139.

#020 [25 Pa. Code §§ 127.441(c) and 135.5]**Recordkeeping.**

(a) The permittee shall maintain and make available, upon request by the Department, the following records of monitored information:

- (1) The date, place (as defined in the permit) and time of sampling or measurements.
- (2) The dates the analyses were performed.
- (3) The company or entity that performed the analyses.
- (4) The analytical techniques or methods used.
- (5) The results of the analyses.
- (6) The operating conditions as existing at the time of sampling or measurement.

(b) The permittee shall retain records of any required monitoring data and supporting information for at least five (5) years from the date of the monitoring, sample, measurement, report or application. Supporting information includes the calibration data and maintenance records and original strip-chart recordings for continuous monitoring instrumentation, and copies of reports required by the permit.

(c) The permittee shall maintain and make available to the Department upon request, records including computerized records that may be necessary to comply with the reporting, recordkeeping and emission statement requirements in 25 Pa. Code Chapter 135 (relating to reporting of sources). In accordance with 25 Pa. Code Chapter 135, § 135.5, such records may include records of production, fuel usage, maintenance of production or pollution control equipment or other information determined by the Department to be necessary for identification and quantification of potential and actual air contaminant emissions.

#021 [25 Pa. Code § 127.441(a)]**Property Rights.**

This permit does not convey any property rights of any sort, or any exclusive privileges.

#022 [25 Pa. Code § 127.447]**Alternative Operating Scenarios.**

The permittee is authorized to make changes at the facility to implement alternative operating scenarios identified in this permit in accordance with 25 Pa. Code § 127.447.

**SECTION B. General State Only Requirements****#023 [25 Pa. Code §135.3]****Reporting**

(a) If the facility is a Synthetic Minor Facility, the permittee shall submit by March 1 of each year an annual emissions report for the preceding calendar year. The report shall include information for all active previously reported sources, new sources which were first operated during the preceding calendar year, and sources modified during the same period which were not previously reported. All air emissions from the facility should be estimated and reported.

(b) A source owner or operator of a Synthetic Minor Facility may request an extension of time from the Department for the filing of an annual emissions report, and the Department may grant the extension for reasonable cause.

#024 [25 Pa. Code §135.4]**Report Format**

If applicable, the emissions reports shall contain sufficient information to enable the Department to complete its emission inventory. Emissions reports shall be made by the source owner or operator in a format specified by the Department.

**SECTION C. Site Level Requirements****I. RESTRICTIONS.****Emission Restriction(s).****# 001 [25 Pa. Code §123.1]****Prohibition of certain fugitive emissions**

The permittee shall not permit the emission of fugitive air contaminants into the outdoor atmosphere from a source other than the following:

- (1) Construction or demolition of buildings or structures.
- (2) Grading, paving and maintenance of roads and streets.
- (3) Use of roads and streets. Emissions from material in or on trucks, railroad cars and other vehicular equipment are not considered as emissions from use of roads and streets.
- (4) Clearing of land.
- (5) Stockpiling of materials.
- (6) Open burning operations.
- (7) Blasting in open pit mines. Emissions from drilling are not considered emissions from blasting.
- (8) Sources and classes of sources other than those identified above, for which the permittee has obtained a determination from the Department that fugitive emissions from the source, after appropriate control, meet the following requirements:

- (a) The emissions are of minor significance with respect to causing air pollution; and
- (b) The emissions are not preventing or interfering with the attainment or maintenance of any ambient air quality standard.

002 [25 Pa. Code §123.2]**Fugitive particulate matter**

The permittee shall not permit fugitive particulate matter to be emitted into the outdoor atmosphere from a source specified in (1) through (8) in condition #001 herein if the emissions are visible at the point the emissions pass outside the permittee's property.

003 [25 Pa. Code §123.41]**Limitations**

The permittee shall not permit the emission of visible air contaminants into the outdoor atmosphere in such a manner that the opacity of the emission is either of the following:

- (1) Equal to or greater than 20% for a period or periods aggregating more than three minutes in any 1 hour.
- (2) Equal to or greater than 60% at any time.

004 [25 Pa. Code §123.42]**Exceptions**

The emission limitations of 25 Pa Code Section 123.41 shall not apply when:

- (1) The presence of uncombined water is the only reason for failure of the emission to meet the limitations;
- (2) The emission results from the operation of equipment used solely to train and test persons in observing the opacity of visible emissions;
- (3) The emissions results from sources specified in (1) through (8) in condition #001 herein.

II. TESTING REQUIREMENTS.**# 005 [25 Pa. Code §127.441]****Operating permit terms and conditions.**

(a) Pursuant to 25 Pa. Code § 139.3, at least 90 calendar days prior to commencing a EPA reference method testing program, a test protocol shall be submitted to the Department for review and approval. Electronic copies shall be sent to the Northcentral Regional Office Air Quality Program Manager and the PSIMS Administrator in Central Office. The test protocol shall meet all applicable requirements specified in the most current version of the Department's Source Testing Manual.

(b) Pursuant to 25 Pa. Code § 139.3, at least 15 calendar days prior to commencing an emission testing program, notification as to the date and time of testing shall be given to the Northcentral Regional Office. Notification shall also be sent to the Division of Source Testing and Monitoring. Notification shall not be made without prior receipt of a protocol acceptance letter from the Department.

(c) If applicable, pursuant to 40 CFR § 60.8(a), 40 CFR § 61.13(f) and 40 CFR § 63.7(g), complete test reports shall be

**SECTION C. Site Level Requirements**

submitted to the Department no later than 60 calendar days after completion of the on-site testing portion of an EPA reference method test program.

(d) Pursuant to 25 Pa. Code § 139.53(b) a complete test report shall include a summary of the emission results on the first page of the report indicating if each pollutant measured is within permitted limits and a statement of compliance or noncompliance with all applicable permit conditions. The summary results will include, at a minimum, the following information:

1. A statement that the owner or operator has reviewed the report from the emissions testing body and agrees with the findings.
2. Permit number(s) and condition(s) which are the basis for the evaluation.
3. Summary of results with respect to each applicable permit condition.
4. Statement of compliance or non-compliance with each applicable permit condition.

(e) Pursuant to 25 Pa. Code § 139.3, all submittals shall meet all applicable requirements specified in the most current version of the Department's Source Testing Manual.

(f) All testing shall be performed in accordance with the provisions of Chapter 139 of the Rules and Regulations of the Department of Environmental Protection.

(g) Pursuant to 25 Pa. Code §§ 139.53(a)(1) and 139.53(a)(3), electronic copies of all submittals, besides notifications, shall be sent to the Northcentral Regional Office Air Quality Program Manager, with deadlines verified. In addition, an electronic copy shall be sent to the PSIMS Administrator in Central Office. Email addresses are provided on the PADEP website.

(h) The permittee shall insure all federal reporting requirements contained in the applicable subpart of 40 CFR are followed, including timelines more stringent than those contained herein. In the event of an inconsistency or any conflicting requirements between state and the federal, the most stringent provision, term, condition, method or rule shall be used by default.

006 [25 Pa. Code §127.441]**Operating permit terms and conditions.**

[Additional authority for this permit condition is derived from the Consent Order & Agreement entered into on August 18, 2005, by and between the Department and Keystone Filler & Mfg. Co.]

The permittee shall test each and all of the Tennant street sweepers once per calendar month to ascertain each Tennant street sweeper's effectiveness at vacuuming and removing the carbon product dust from both the in-plant roadways and other surfaces as well as the adjacent public roadways.

007 [25 Pa. Code §139.1]**Sampling facilities.**

Upon the request of the Department, the permittee shall provide adequate sampling ports, safe sampling platforms and adequate utilities for the performance by the Department of tests on a source. The Department will set forth, in the request, the time period in which the facilities shall be provided as well as the specifications for such facilities.

008 [25 Pa. Code §139.11]**General requirements.**

(1) As specified in 25 Pa. Code Section 139.11(1), performance tests shall be conducted while the respective source is operating at maximum routine operating conditions or under such other conditions, within the capacity of the equipment, as may be requested by the Department.

(2) As specified in 25 Pa. Code Section 139.11(2), the Department will consider test results for approval where sufficient information is provided to verify the source conditions existing at the time of the test and where adequate data is available to show the manner in which the test was conducted. Information submitted to the Department shall include, as a minimum all of the following:

- (a) A thorough source description, including a description of any air cleaning devices and the flue.
- (b) Process conditions, for example, the charging rate of raw materials or the rate of production of final product, boiler pressure, oven temperature and other conditions which may effect emissions from the process.
- (c) The location of sampling ports.
- (d) Effluent characteristics, including velocity, temperature, moisture content, gas density (percentage CO, CO₂, O₂ and N₂), static and barometric pressures.

**SECTION C. Site Level Requirements**

- (e) Sample collection techniques employed, including procedures used, equipment descriptions and data to verify that isokinetic sampling for particulate matter collection occurred and that acceptable test conditions were met.
 (f) Laboratory procedures and results.
 (g) Calculated results.

III. MONITORING REQUIREMENTS.**# 009 [25 Pa. Code §123.43]****Measuring techniques**

Visible emissions may be measured using either of the following:

- (1) A device approved by the Department and maintained to provide accurate opacity measurements.
- (2) Observers, trained and qualified to measure plume opacity with the naked eye or with the aid of any devices approved by the Department.

010 [25 Pa. Code §127.441]**Operating permit terms and conditions.**

[Additional authority for this permit condition is derived from the Consent Order & Agreement entered into on August 18, 2005, by and between the Department and Keystone Filler & Mfg. Co.]

On each and every day and during each and every shift the Muncy Creek Township Plant is operated the permittee shall monitor each of the air cleaning devices listed below for pressure differential across the air cleaning device, for exhaust visible emissions, for ductwork and loadout visible fugitive emissions, and for maintenance performed.

- (1) Control Device C304A (Griffin model JA-140-SA)
- (2) Control Device C304B (Mikropul model 9S-10-20)
- (3) Control Device C304C (Griffin model JA-200-SA)
- (4) Control Device C305 (Mikropul model 400S-TRH-10)
- (5) Control Device C305A (Mac model 96 FRB 21)
- (6) Control Device C307A (FlexKleen model 100-WRT-160)
- (7) #2 mill railcar loadout hood associated with Source P304
- (8) bulk railcar loadout hood associated with Source P307

011 [25 Pa. Code §127.441]**Operating permit terms and conditions.**

[Additional authority for this permit condition is derived from the Consent Order & Agreement entered into on August 18, 2005, by and between the Department and Keystone Filler & Mfg. Co.]

On each and every day and during each and every shift the Muncy Creek Township Plant is operated the permittee, or personnel designated by the permittee, shall perform surveillance of the Muncy Creek Township Plant from each and all of the off site monitoring points identified as View North, View South and View West on the plot plan contained in the Consent Order & Agreement entered into on August 18, 2005, by and between the Department and Keystone Filler & Mfg. Co. This surveillance shall be performed for the presence, or lack thereof, of any visible and/or fugitive emissions from general Muncy Creek Township Plant operations and from each and all of the air contamination sources and respective air cleaning devices at the Muncy Creek Township Plant. In the event this surveillance reveals that visible and/or fugitive emissions are present from general Muncy Creek Township Plant operations or from any of the air contamination sources and respective air cleaning devices, the permittee shall immediately shutdown the general Muncy Creek Township Plant operations, the air contamination sources controlled by the respective air cleaning devices and/or the air cleaning devices themselves and appropriate corrections and/or repairs shall be effected.

IV. RECORDKEEPING REQUIREMENTS.**# 012 [25 Pa. Code §127.441]****Operating permit terms and conditions.**

[Additional authority for this permit condition is derived from the Consent Order & Agreement entered into on August 18, 2005, by and between the Department and Keystone Filler & Mfg. Co.]

The permittee shall maintain daily records for each air cleaning device in condition #010 herein. These daily records shall

**SECTION C. Site Level Requirements**

log the pressure differential across the device, report the exhaust visible emissions observed, report the ductwork and loadout visible fugitive emissions observed, and the maintenance performed as described in condition #022 herein. These daily records logging the pressure differential across the device, reporting the exhaust visible emissions observed, reporting the ductwork and loadout visible fugitive emissions observed, and the maintenance performed as described in condition #022 herein, shall be taken and logged twice daily during daylight operating hours a minimum of six (6) hours apart from each other. The records shall also identify the individual inputting each set of data.

013 [25 Pa. Code §127.441]**Operating permit terms and conditions.**

[Additional authority for this permit condition is derived from the Consent Order & Agreement entered into on August 18, 2005, by and between the Department and Keystone Filler & Mfg. Co.]

The permittee shall maintain daily work records for each and all of the active clean-up crew employees. The daily work records shall log the date, employee name, the total hours worked on a daily basis and a description of the specific work activities performed.

014 [25 Pa. Code §127.441]**Operating permit terms and conditions.**

[Additional authority for this permit condition is derived from the Consent Order & Agreement entered into on August 18, 2005, by and between the Department and Keystone Filler & Mfg. Co.]

The permittee shall maintain records of the daily surveillance performed at the Muncy Creek Township Plant as required by condition #011 herein. The records shall identify the date, the time of surveillance, the individual conducting the surveillance, the occurrence of any visible and/or fugitive emissions and corrective action(s) taken to abate each recorded occurrence.

015 [25 Pa. Code §127.441]**Operating permit terms and conditions.**

[Additional authority for this permit condition is derived from the Consent Order & Agreement entered into on August 18, 2005, by and between the Department and Keystone Filler & Mfg. Co.]

The permittee shall maintain daily operating records for each and all of the facility's Tennant street sweepers for any and all days that each and all of the Tennant street sweepers are operated. The daily operating records shall log the date, operator name, the total hours of operation on a daily basis, the areas swept and/or maintained, the number of times each Tennant street sweeper was emptied on a daily basis including an estimation of the total weight/volume of material emptied and the type of maintenance performed on each Tennant street sweeper, as applicable. Additionally, the permittee shall maintain a record of the results of the sweeper's monthly effectiveness testing.

016 [25 Pa. Code §135.5]**Recordkeeping**

The permittee shall maintain such records including computerized records as may be necessary to comply with 25 Pa. Code Sections 135.3 and 135.21. These may include records of production, fuel usage, maintenance of production or pollution control equipment or other information determined by the Department to be necessary for identification and quantification of potential and actual air contaminant emissions.

All records generated pursuant to this condition shall be retained for a minimum of five (5) years and shall be made available to the Department upon request.

V. REPORTING REQUIREMENTS.**# 017 [25 Pa. Code §127.441]****Operating permit terms and conditions.**

[Additional authority for this permit condition is derived from the Consent Order & Agreement entered into on August 18, 2005, by and between the Department and Keystone Filler & Mfg. Co.]

The permittee shall submit the following records to the Department on a quarterly basis:

(1) Copies of the daily operating records for each of the facility's Tennant street sweepers for the respective calendar

**SECTION C. Site Level Requirements**

quarter.

(2) Copies of the monthly inspection and effectiveness test reports for each of the facility's Tennant street sweepers for the respective calendar quarter.

(3) Copies of the daily records for each air cleaning device for the respective calendar quarter.

(4) Copies of the daily work records for the respective calendar quarter.

(5) Copies of the daily surveillance records of the "Muncy Creek Township Plant" for the respective calendar quarter.

(6) Copies of the weekly meeting minutes for the respective calendar quarter.

The quarterly reports shall be submitted to the Department by no later than May 1 for the preceding January 1 to March 31 time period, August 1 for the preceding April 1 to June 30 time period, October 1 for the preceding July 1 to September 30 time period and February 1 for the preceding October 1 to December 31 time period.

018 [25 Pa. Code §127.441]**Operating permit terms and conditions.**

The permittee shall submit all requested reports in accordance with the Department's suggested format.

019 [25 Pa. Code §127.442]**Reporting requirements.**

(a) The permittee shall report malfunctions, emergencies or incidents of excess emissions to the Department. A malfunction is any sudden, infrequent, and not reasonably preventable failure of air pollution control equipment, process equipment, or a process to operate in a normal or usual manner. An emergency is any situation arising from sudden and reasonably unforeseeable events beyond the control of the owner or operator of a facility which requires immediate corrective action to restore normal operation and which causes the emission source to exceed emissions, due to unavoidable increases in emissions attributable to the situation. An emergency shall not include situations caused by improperly designed equipment, lack of preventive maintenance, careless or improper operation, or operator error.

(b) When the malfunction, emergency or incident of excess emissions poses an imminent danger to the public health, safety, welfare, or environment, it shall be reported to the Department and the County Emergency Management Agency by telephone within one (1) hour after the discovery of the malfunction, emergency or incident of excess emissions. The owner or operator shall submit a written or emailed report of instances of such malfunctions, emergencies or incidents of excess emissions to the Department within three (3) business days of the telephone report.

(c) The report shall describe the following:

1. name, permit or authorization number, and location of the facility,
2. nature and cause of the malfunction, emergency or incident,
3. date and time when the malfunction, emergency or incident was first observed,
4. expected duration of excess emissions,
5. estimated rate of emissions,
6. corrective actions or preventative measures taken.

(d) Any malfunction, emergency or incident of excess emissions that is not subject to the notice requirements of paragraph (b) of this condition shall be reported to the Department by telephone within 24 hours (or by 4:00 PM of the next business day, whichever is later) of discovery and in writing or by e-mail within five (5) business days of discovery. The report shall contain the same information required by paragraph (c), and any permit specific malfunction reporting requirements.

(e) During an emergency an owner or operator may continue to operate the source at their discretion provided they submit justification for continued operation of a source during the emergency and follow all the notification and reporting requirements in accordance with paragraphs (b)-(d), as applicable, including any permit specific malfunction reporting requirements.

(f) Reports regarding malfunctions, emergencies or incidents of excess emissions shall be submitted to the appropriate DEP Regional Office Air Program Manager.

(g) Any emissions resulted from malfunction or emergency are to be reported in the annual emissions inventory report, if the annual emissions inventory report is required by permit or authorization.

020 [25 Pa. Code §135.3]**Reporting**

(1) A person who owns or operates a source to which 25 Pa. Code Chapter 135 applies, and who has previously been advised by the Department to submit an annual Air Information Management Systems (AIMS) report, shall submit by March 1 of each year an annual AIMS report for the preceding calendar year. The report shall include information for all previously

**SECTION C. Site Level Requirements**

reported sources, new sources which were first operated during the preceding calendar year and sources modified during the same period which were not previously reported.

(2) A person who receives initial notification by the Department that an annual AIMS report is necessary shall submit an initial annual AIMS report within 60 days after receiving the notification or by March 1 of the year following the year for which the report is required, whichever is later.

(3) A source owner or operator may request an extension of time from the Department for the filing of an annual AIMS report, and the Department may grant the extension for reasonable cause.

VI. WORK PRACTICE REQUIREMENTS.**# 021 [25 Pa. Code §123.1]****Prohibition of certain fugitive emissions**

The permittee shall take all reasonable actions to prevent particulate matter from becoming airborne from any source specified in (1) through (8) in condition #001 herein. These actions shall include, but not limited to, the following:

(1) Use, where possible, of water or chemicals for control of dust in the demolition of buildings or structures, construction operations, the grading of roads or the clearing of land.

(2) Application of asphalt, oil, or suitable chemicals on dirt roads, material stockpiles and other surfaces which may give rise to airborne dusts.

(3) Paving and maintenance of roadways.

(4) Prompt removal of earth or other material from paved streets onto which earth or other material has been transported by trucking or earth moving equipment, erosion by water, or other means.

022 [25 Pa. Code §127.441]**Operating permit terms and conditions.**

[Additional authority for this permit condition is derived from the Consent Order & Agreement entered into on August 18, 2005, by and between the Department and Keystone Filler & Mfg. Co.]

The permittee shall take all reasonable actions to prevent carbon product dust and/or any other particulate matter from becoming airborne from the raw materials storage area identified as Area A on the plot plan contained in the Consent Order & Agreement entered into on August 18, 2005, by and between the Department and Keystone Filler & Mfg. Co. These actions shall include, but not be limited to, the use in the raw materials storage area, where possible, of asphalt, oil, water or suitable chemicals on material stockpiles and other surfaces which may give rise to airborne dusts; the paving and maintenance of the raw materials storage area; and, the prompt removal of carbon product dust and/or any other particulate matter from the raw materials storage area onto which carbon product dust and/or any other particulate matter has been transported by trucking or other transport equipment, erosion by water, or other means.

023 [25 Pa. Code §127.441]**Operating permit terms and conditions.**

[Additional authority for this permit condition is derived from the Consent Order & Agreement entered into on August 18, 2005, by and between the Department and Keystone Filler & Mfg. Co.]

The permittee shall immediately close the Railroad Street coal storage building overhead door after truck delivery of raw products and this door shall remain closed at all times no trucks are delivering raw products.

024 [25 Pa. Code §127.441]**Operating permit terms and conditions.**

[Additional authority for this permit condition is derived from the Consent Order & Agreement entered into on August 18, 2005, by and between the Department and Keystone Filler & Mfg. Co.]

The permittee shall perform in-plant carbon product dust transport using a tarped truck and/or trailer, a closed bucket loader, or other contained transport system. The trucks and/or trailers need not be tarped if the in-plant carbon product dust is sufficiently wet to prevent the emission of fugitive carbon product dust.

025 [25 Pa. Code §127.441]**Operating permit terms and conditions.**

[Additional authority for this permit condition is derived from the Consent Order & Agreement entered into on August 18, 2005, by and between the Department and Keystone Filler & Mfg. Co.]

**SECTION C. Site Level Requirements**

In the event the air cleaning devices monitoring described in condition #010 herein reveals that the pressure differential across the air cleaning device(s) is not in compliance with good operating practices, exhaust visible emissions are present, ductwork and/or loadout visible fugitive emissions are present, or maintenance is required, both the air contamination source(s) controlled by the respective air cleaning device(s) and the air cleaning device(s) shall be immediately shutdown and appropriate corrections and/or repairs effected.

026 [25 Pa. Code §127.441]**Operating permit terms and conditions.**

[Additional authority for this permit condition is derived from the Consent Order & Agreement entered into on August 18, 2005, by and between the Department and Keystone Filler & Mfg. Co.]

The permittee shall hold weekly meetings for the Muncy Creek Township Plant employees discussing environmental matters occurring the previous week and up to the date upon which the meeting is held, specifically, problems encountered, corrections made, recommendations for avoidance of said problems occurring, etc., and maintain meeting minutes of all matters discussed.

027 [25 Pa. Code §127.441]**Operating permit terms and conditions.**

[Additional authority for this permit condition is derived from the Consent Order & Agreement entered into on August 18, 2005, by and between the Department and Keystone Filler & Mfg. Co.]

The permittee shall provide training to all new employees within one (1) week of their being hired to provide guidance to and ensure all new employees are aware of their responsibilities towards achieving and/or maintaining compliance with the Department's Rules and Regulations. At a minimum, all new employees shall:

- (1) Be informed of all requirements specified in this operating permit.
- (2) Attend and satisfactorily complete an OSHA certified lift truck course.
- (3) Have at least 40 hours experience of on the job training with an experienced operator prior to performing the job on their own.
- (4) Have been informed to report any fugitive emissions observed and to immediately shut down equipment emitting fugitive emissions until repairs have been made.

028 [25 Pa. Code §127.441]**Operating permit terms and conditions.**

[Additional authority for this permit condition is derived from the Consent Order & Agreement entered into on August 18, 2005, by and between the Department and Keystone Filler & Mfg. Co.]

The permittee shall operate one (1) of the Tennant model 830 street sweepers on all in-plant roadways and parking and storage areas and on all adjacent public roadways surrounding the Muncy Creek Township Plant for a minimum of sixteen (16) hours on all calendar week days. If the Muncy Creek Township Plant is operated less than sixteen (16) hours on any given calendar week day, the one (1) Tennant model 830 street sweeper shall be operated on all in-plant roadways and parking and storage areas and on all adjacent public roadways surrounding the Muncy Creek Township Plant for as many hours as the Muncy Creek Township Plant is operated. The one (1) of the Tennant model 830 street sweepers referenced by this paragraph shall be the primary choice of Tennant street sweepers used, with the Tennant model 810 street sweeper being a secondary choice due to the Tennant model 830 street sweepers needing repair and/or maintenance.

029 [25 Pa. Code §127.441]**Operating permit terms and conditions.**

[Additional authority for this permit condition is derived from the Consent Order & Agreement entered into on August 18, 2005, by and between the Department and Keystone Filler & Mfg. Co.]

The permittee shall operate one (1) of the Tennant model 830 street sweepers on all in-plant roadways and parking and storage areas and on all adjacent public roadways surrounding the Muncy Creek Township Plant for a minimum of ten (10) hours on all calendar weekend days. If the Muncy Creek Township Plant is operated less than ten (10) hours on any given calendar weekend day, the one (1) Tennant model 830 street sweeper shall be operated on all in-plant roadways and parking and storage areas and on all adjacent public roadways surrounding the Muncy Creek Township Plant for as many hours as the Muncy Creek Township Plant is operated. The one (1) of the Tennant model 830 street sweepers referenced

**SECTION C. Site Level Requirements**

by this paragraph shall be the primary choice of Tennant street sweepers used, with the Tennant model 810 street sweeper being a secondary choice due to the Tennant model 830 street sweepers needing repair and/or maintenance.

030 [25 Pa. Code §127.441]**Operating permit terms and conditions.**

[Additional authority for this permit condition is derived from the Consent Order & Agreement entered into on August 18, 2005, by and between the Department and Keystone Filler & Mfg. Co.]

At any time any of the Tennant street sweepers are not being operated, for whatever reason, on either the in-plant roadways and parking and storage areas and/or on the adjacent public roadways surrounding the Muncy Creek Township Plant, the permittee shall take all reasonable actions to prevent particulate matter from becoming airborne from either the in-plant roadways and parking and storage areas and/or on the adjacent public roadways surrounding the Muncy Creek Township Plant. These actions shall include, but not be limited to, the use, where possible, of water or chemicals for control of dust in the grading of roads or clearing of land, the application of asphalt, oil, water or suitable chemicals on dirt roads, material stockpiles and other surfaces which may give rise to airborne dusts, the paving and maintenance of roadways, and/or the prompt removal of earth or other material from paved streets, specifically all the in-plant roadways and parking and storage areas and on all the adjacent public roadways surrounding the Muncy Creek Township Plant onto which earth or other material has been transported by trucking or earth moving equipment, erosion by water, or other means.

VII. ADDITIONAL REQUIREMENTS.**# 031 [25 Pa. Code §121.7]****Prohibition of air pollution.**

The permittee shall not permit air pollution as that term is defined in the Pennsylvania Air Pollution Control Act (35 P.S. Sections 4001 - 4015).

032 [25 Pa. Code §123.31]**Limitations**

The permittee shall not permit the emission of any malodorous air contaminants into the outdoor atmosphere from any source in such a manner that the malodors are detectable outside the property of the permittee on whose land the source is being operated.

033 [25 Pa. Code §127.441]**Operating permit terms and conditions.**

[Additional authority for this permit condition is derived from the Consent Order & Agreement entered into on August 18, 2005, by and between the Department and Keystone Filler & Mfg. Co.]

The permittee shall maintain an adequately anchored single railroad tie protective barrier on the ground at the perimeter of all Muncy Creek Township Plant production and/or facility buildings aligning the area identified as Area F, on the plot plan contained in the Consent Order & Agreement entered into on August 18, 2005, by and between the Department and Keystone Filler & Mfg. Co., to prevent any and all vehicles operating on the Muncy Creek Township Plant property from striking said production and/or facility buildings and/or creating holes in said production and/or facility buildings. In the event any of the railroad ties described above are damaged, or any of the Muncy Creek Township Plant production and/or facility buildings aligning the area identified as Area F are damaged by vehicles operating on the Muncy Creek Township Plant property strike said production and/or facility buildings and creating holes in said production and/or facility buildings, the permittee shall initiate and complete repairs to the railroad ties and/or said production and/or facility buildings within seven (7) calendar days.

034 [25 Pa. Code §127.441]**Operating permit terms and conditions.**

[Additional authority for this permit condition is derived from the Consent Order & Agreement entered into on August 18, 2005, by and between the Department and Keystone Filler & Mfg. Co.]

The permittee shall maintain the condition of pavement on the entire southern portion of the Muncy Creek Township Plant property area identified as Area H and totally surrounding those portions of the Muncy Creek Township Plant property area identified as Area I and Area K with an adequate bituminous asphalt material. Area H, Area I and Area K are defined on the plot plan contained in the Consent Order & Agreement entered into on August 18, 2005, by and between the Department

**SECTION C. Site Level Requirements**

and Keystone Filler & Mfg. Co.

035 [25 Pa. Code §129.14]**Open burning operations**

The permittee shall not permit the open burning of material at this facility unless in accordance with 25 Pa. Code Section 129.14.

VIII. COMPLIANCE CERTIFICATION.

No additional compliance certifications exist except as provided in other sections of this permit including Section B (relating to State Only General Requirements).

IX. COMPLIANCE SCHEDULE.

No compliance milestones exist.

**SECTION D. Source Level Requirements**

Source ID: 031

Source Name: NATURAL GAS-FIRED COMBUSTION UNIT

Source Capacity/Throughput:

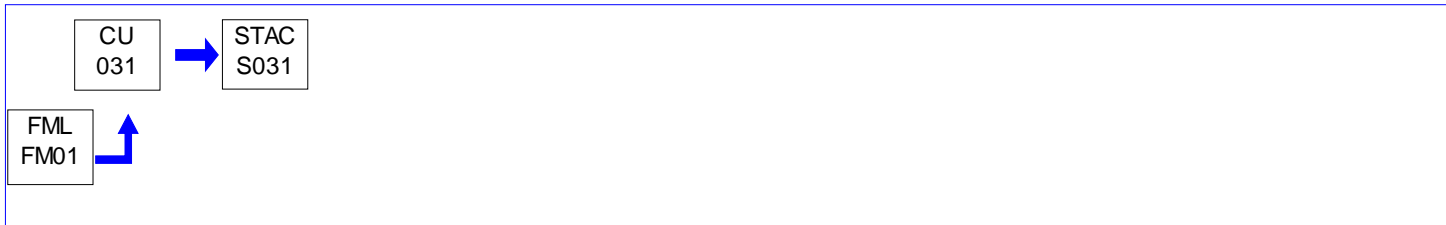
**I. RESTRICTIONS.****Emission Restriction(s).**

001 [25 Pa. Code §123.22]

Combustion units

The permittee shall not permit the emission of sulfur oxides, expressed as sulfur dioxide (SO₂), into the outdoor atmosphere from Source 031 in excess of the rate of 4 pounds per million Btu of heat input over any 1-hour period.

II. TESTING REQUIREMENTS.

No additional testing requirements exist except as provided in other sections of this permit including Section B (State Only General Requirements).

III. MONITORING REQUIREMENTS.

No additional monitoring requirements exist except as provided in other sections of this permit including Section B (State Only General Requirements).

IV. RECORDKEEPING REQUIREMENTS.

No additional record keeping requirements exist except as provided in other sections of this permit including Section B (State Only General Requirements).

V. REPORTING REQUIREMENTS.

No additional reporting requirements exist except as provided in other sections of this permit including Section B (State Only General Requirements).

VI. WORK PRACTICE REQUIREMENTS.

No additional work practice requirements exist except as provided in other sections of this permit including Section B (State Only General Requirements).

VII. ADDITIONAL REQUIREMENTS.

002 [25 Pa. Code §127.441]

Operating permit terms and conditions.

Source 031 is a 150,000 Btu per hour, natural gas-fired HB Smith model GB100-W-7 HSID low pressure boiler located in the main office.

**SECTION D. Source Level Requirements**

Source ID: P301

Source Name: #3 DRYER

Source Capacity/Throughput:

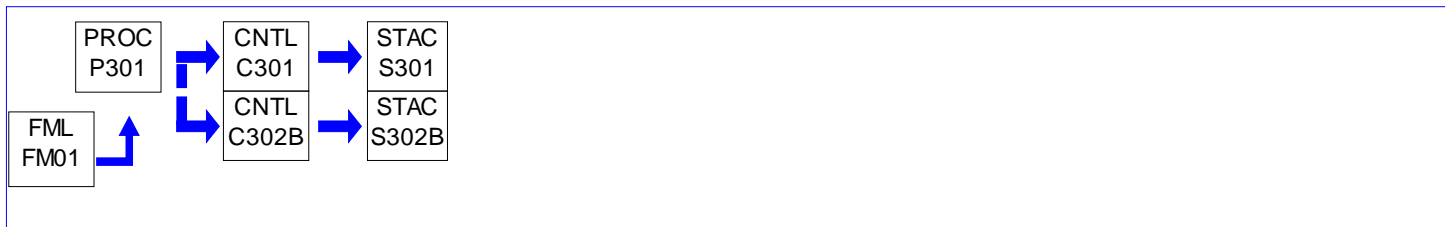
**I. RESTRICTIONS.****Emission Restriction(s).****# 001 [25 Pa. Code §123.13]****Processes**

The permittee shall not permit the emission of particulate matter into the outdoor atmosphere from Source P301 in such a manner that the concentration of particulate matter in the exhaust from Control Device C301 exceeds 0.04 grains per dry standard cubic foot of effluent gas volume.

002 [25 Pa. Code §123.21]**General**

The permittee may not permit the emission of sulfur oxides, expressed as SO₂, into the outdoor atmosphere from Source P301 in such a manner that the concentration of the sulfur oxides in the exhaust from Control Device C301 exceeds 500 parts per million, by volume, dry basis.

Fuel Restriction(s).**# 003 [25 Pa. Code §127.441]****Operating permit terms and conditions.**

The rotary dryer incorporated in Source P301 shall only be fired on natural gas.

II. TESTING REQUIREMENTS.

No additional testing requirements exist except as provided in other sections of this permit including Section B (State Only General Requirements).

III. MONITORING REQUIREMENTS.

No additional monitoring requirements exist except as provided in other sections of this permit including Section B (State Only General Requirements).

IV. RECORDKEEPING REQUIREMENTS.

No additional record keeping requirements exist except as provided in other sections of this permit including Section B (State Only General Requirements).

V. REPORTING REQUIREMENTS.

No additional reporting requirements exist except as provided in other sections of this permit including Section B (State Only General Requirements).

**SECTION D. Source Level Requirements****VI. WORK PRACTICE REQUIREMENTS.****# 004 [25 Pa. Code §127.441]****Operating permit terms and conditions.**

The storage and handling of the material collected in Control Device C301 shall not at any time result in the emission of fugitive air contaminants in excess of the limitations specified in 25 Pa. Code Section 123.1.

005 [25 Pa. Code §127.441]**Operating permit terms and conditions.**

The permittee shall keep on hand a sufficient quantity of spare fabric collector bags for Control Device C301 in order to be able to immediately replace any bags requiring replacement due to deterioration resulting from routine operation of Source P301 and Control Device C301.

VII. ADDITIONAL REQUIREMENTS.**# 006 [25 Pa. Code §127.441]****Operating permit terms and conditions.**

Source P301 is the #3 Dryer Operation comprised of the following air contamination sources:

- (a) feed bin
- (b) 18"x 30' wet material feed belt
- (c) 6 ton per hour, natural gas-fired McDermott 6'x 35' rotary coal dryer equipped with a 3.0 million Btu per hour burner
- (d) 16"x 36"x 40' bucket elevator
- (e) three screw conveyors ((1) feeds material from Mikropul hopper to dryer discharge, (2) feeds material from bucket elevator to down chutes (down chutes feed either the screw conveyor for the railcar load out, the Raymond mill associated with Source P302 or the Jacobson crusher associated with Source P302 and (3) feeds material from down chute to railcar load out)
- (f) railcar load out spout

The air contaminant emissions from Source 301 shall be controlled by a Mikropul model 81S-10-20 (Control Device C301) reverse pulse fabric collector with pickup points located at the rotary dryer and the bucket elevator.

The air contaminant emissions from the railcar load out spout incorporated in Source P301 shall be controlled by the Mikropul model 81S-10-20 (Control Device C302B) fabric collector associated with Source P302.

007 [25 Pa. Code §127.441]**Operating permit terms and conditions.**

Source ID P301 was damaged by a fire in 2018. Prior to initiating repairs and putting Source ID P301 back into service, the permittee shall contact the Department's Northcentral Regional Office's Air Quality Program to discuss the proposed repairs.

**SECTION D. Source Level Requirements**

Source ID: P302

Source Name: #1 MILL

Source Capacity/Throughput:

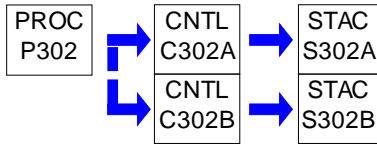
**I. RESTRICTIONS.****Emission Restriction(s).****# 001 [25 Pa. Code §123.13]****Processes**

The permittee shall not permit the emission of particulate matter into the outdoor atmosphere from Source P302 in such a manner that the concentration of particulate matter in the exhaust from Control Device C302A or Control Device 302B exceeds 0.04 grains per dry standard cubic foot of effluent gas volume.

II. TESTING REQUIREMENTS.

No additional testing requirements exist except as provided in other sections of this permit including Section B (State Only General Requirements).

III. MONITORING REQUIREMENTS.

No additional monitoring requirements exist except as provided in other sections of this permit including Section B (State Only General Requirements).

IV. RECORDKEEPING REQUIREMENTS.

No additional record keeping requirements exist except as provided in other sections of this permit including Section B (State Only General Requirements).

V. REPORTING REQUIREMENTS.

No additional reporting requirements exist except as provided in other sections of this permit including Section B (State Only General Requirements).

VI. WORK PRACTICE REQUIREMENTS.**# 002 [25 Pa. Code §127.441]****Operating permit terms and conditions.**

The storage and handling of the material collected in Control Device C302A, Control Device C302B and the Young Industries fabric collector shall not at any time result in the emission of fugitive air contaminants in excess of the limitations specified in 25 Pa. Code Section 123.1.

VII. ADDITIONAL REQUIREMENTS.**# 003 [25 Pa. Code §127.441]****Operating permit terms and conditions.**

Source P302 is the #1 Mill Operation comprised of the following air contamination sources:

- (a) 3 ton per hour, Raymond high-side roller mill
- (b) 9" screw conveyor (feeds material from Raymond mill cyclone to Rota-Sieve screen)
- (c) Rota-Sieve screen model #RS-301A

**SECTION D. Source Level Requirements**

- (d) screen oversize bin
- (e) packer bin
- (f) Black Products two bag packer
- (g) shop-fabricated bag flattener
- (h) shop-fabricated bag stacking template
- (i) two truck load out spouts
- (j) railcar load out spout
- (k) Jacobson model P24214-D hammer mill crusher
- (l) three 9" screw conveyors (associated with Jacobson crusher)

The air contaminant emissions from Source 302 shall be controlled by a Griffin model JA-140-SA reverse pulse fabric collector (Control Device C302A) with a pickup point located at the roller mill, by a Mikropul model 81S-10-20 reverse pulse fabric collector (Control Device C302B) with pickup points located at the oversize bin, the bag packer and the bag flattener, as well as at the railcar load out spout incorporated in Source P301, by an inside-exhausting Young Industries model VM96 54 reverse pulse fabric collector with a pickup point located at the Jacobson crusher, the railcar load out and the two truck load out spouts and by an inside-exhausting Flex Kleen model Buhler Miag nuisance dust collector which controls the fugitive air contaminant emissions generated inside the mill enclosure.

**SECTION D. Source Level Requirements**

Source ID: P303

Source Name: ACM MILL

Source Capacity/Throughput:

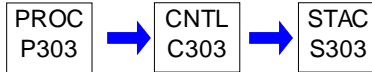
**I. RESTRICTIONS.****Emission Restriction(s).**

001 [25 Pa. Code §123.13]

Processes

The permittee shall not permit the emission of particulate matter into the outdoor atmosphere from Source P303 in such a manner that the concentration of particulate matter in the exhaust from Control Device C303 exceeds 0.04 grains per dry standard cubic foot of effluent gas volume.

II. TESTING REQUIREMENTS.

No additional testing requirements exist except as provided in other sections of this permit including Section B (State Only General Requirements).

III. MONITORING REQUIREMENTS.

002 [25 Pa. Code §127.441]

Operating permit terms and conditions.

Control Device C303 and the Mikropul Farr cartridge filter shall each be equipped with instrumentation to continuously monitor the differential pressure across the respective collector.

IV. RECORDKEEPING REQUIREMENTS.

No additional record keeping requirements exist except as provided in other sections of this permit including Section B (State Only General Requirements).

V. REPORTING REQUIREMENTS.

No additional reporting requirements exist except as provided in other sections of this permit including Section B (State Only General Requirements).

VI. WORK PRACTICE REQUIREMENTS.

003 [25 Pa. Code §127.441]

Operating permit terms and conditions.

The permittee shall keep on hand a sufficient quantity of spare fabric collector bags for Control Device C303 and cartridge filters for the Mikropul Farr cartridge filter in order to be able to immediately replace any bags or filters requiring replacement due to deterioration resulting from routine operation of Source P303 and Control Device C303 or the Mikropul Farr cartridge filter.

004 [25 Pa. Code §127.441]

Operating permit terms and conditions.

The storage and handling of the material collected in Control Device C303, the Mikropul Farr cartridge filter and the Buhler Miag fabric collector shall not at any time result in the emission of fugitive air contaminants in excess of the limitations specified in 25 Pa. Code Section 123.1.

**SECTION D. Source Level Requirements****VII. ADDITIONAL REQUIREMENTS.****# 005 [25 Pa. Code §127.441]****Operating permit terms and conditions.**

Source P303 is the ACM Mill comprised of the following air contamination sources:

- (a) feed bin
- (b) 9" feed screw (feeds material from feed bin to ACM grinding mill)
- (c) 2.5 ton per hour ACM 75 Mikropul grinding system
- (d) Prater Rota-Sieve #151A
- (e) #2 storage silo
- (f) Carmen model CD12 vacuum densifier
- (g) packer bin
- (h) two baggers
- (i) bag flattener
- (j) bag cleaner

The air contaminant emissions from Source P303 shall be controlled by a Mikropul model 10S-10-100 reverse pulse fabric collector (Control Device C303) with pickup points located at the ACM mill and the #2 silo, by an inside-exhausting Mikropul Farr model 13XT cartridge filter with a pickup point located at the vacuum densifier, by an inside-exhausting Buhler Miag fabric collector with pickup points located at the packer bin, the two baggers, the bag flattener and the bag cleaner and by an inside-exhausting nuisance dust fabric collector (make and model unknown) which controls the fugitive air contaminant emissions generated inside the mill enclosure.

**SECTION D. Source Level Requirements**

Source ID: P304

Source Name: #2 MILL

Source Capacity/Throughput:

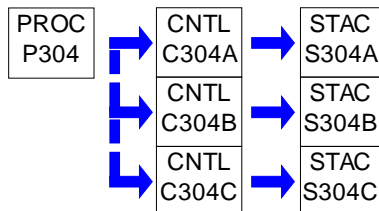
**I. RESTRICTIONS.****Emission Restriction(s).****# 001 [25 Pa. Code §123.13]****Processes**

The permittee shall not permit the emission of particulate matter into the outdoor atmosphere from Source P304 in such a manner that the concentration of particulate matter in the exhaust from Control Device C304A, Control Device C304B or Control Device C304C exceeds 0.04 grains per dry standard cubic foot of effluent gas volume.

II. TESTING REQUIREMENTS.

No additional testing requirements exist except as provided in other sections of this permit including Section B (State Only General Requirements).

III. MONITORING REQUIREMENTS.**# 002 [25 Pa. Code §127.441]****Operating permit terms and conditions.**

[Additional authority for this permit condition is derived from the Consent Order & Agreement entered into on August 18, 2005, by and between the Department and Keystone Filler & Mfg. Co.]

Control Device C304A, Control Device C304B and Control Device C304C shall each be equipped with instrumentation to continuously monitor the differential pressure across the respective collector.

IV. RECORDKEEPING REQUIREMENTS.

No additional record keeping requirements exist except as provided in other sections of this permit including Section B (State Only General Requirements).

V. REPORTING REQUIREMENTS.

No additional reporting requirements exist except as provided in other sections of this permit including Section B (State Only General Requirements).

VI. WORK PRACTICE REQUIREMENTS.**# 003 [25 Pa. Code §127.441]****Operating permit terms and conditions.**

The air contaminant emissions within the air space above the railcar load out spout incorporated in Source P304 shall be controlled by a 6 foot long by 6 foot wide hood equipped with 12 foot long vertically-oriented plastic strips along the entire perimeter of the hood and ducted to Control Device C304C. The respective hood shall be ducted to Control Device C304C, the plastic strips shall be hanging vertically in place and Control Device C304C shall be operating at all times that loading operations are occurring at the railcar load out spout incorporated in Source P304.

**SECTION D. Source Level Requirements****# 004 [25 Pa. Code §127.441]****Operating permit terms and conditions.**

The railcar load out spout incorporated in Source P304 shall not be simultaneously operated with the bulk railcar load out spout incorporated in Source P307. When the railcar load out spout incorporated in Source P304 is being used, the ductwork from the bulk railcar load out spout incorporated in Source P307 shall be closed off. When the bulk railcar load out spout incorporated in Source P307 is being used, the ductwork from the railcar load out spout incorporated in Source P304 shall be closed off.

005 [25 Pa. Code §127.441]**Operating permit terms and conditions.**

The permittee shall keep on hand a sufficient quantity of spare fabric collector bags for Control Device C304A, Control Device C304B and Control Device C304C in order to be able to immediately replace any bags requiring replacement due to deterioration resulting from routine operation of Source P304 and Control Device C304A, Control Device C304B or Control Device C304C.

006 [25 Pa. Code §127.441]**Operating permit terms and conditions.**

The storage and handling of the material collected in Control Device C304A, Control Device C304B, Control Device C304C and the Griffin fabric collector shall not at any time result in the emission of fugitive air contaminants in excess of the limitations specified in 25 Pa. Code Section 123.1.

VII. ADDITIONAL REQUIREMENTS.**# 007 [25 Pa. Code §127.441]****Operating permit terms and conditions.**

Source P304 is the #2 Mill Operation comprised of the following air contamination sources:

- (a) feed bin
- (b) 5 ton per hour, Raymond high-side roller mill
- (c) four 9" screw conveyors ((1) feeds material from feed bin to Raymond mill, (2) feeds material from Raymond mill to railcar load out, (3) feeds material from Raymond mill to bag packers and screw conveyor for finished product bin and (4) feeds material from screw conveyor to finished product bin)
- (d) railcar load out spout and 6'x6' hood
- (e) truck load out spout (located under finished material bin)
- (f) bag packers
- (g) finished material bin

The air contaminant emissions from Source P304 shall be controlled by a Griffin model JA-140-SA reverse pulse fabric collector (Control Device C304A) with pickup points located at the mill, the bag packers and finished material bin, by a Mikropul model 9S-10-20 reverse pulse fabric collector (Control Device C304B) with a pickup point located at the railcar load out spout, by a Griffin model JA-200-SA fabric collector (Control Device C304C) with a pickup point located at the 6'x6' railcar load out hood and by an inside-exhausting Griffin fabric collector with a pickup point located at the truck load out spout under the finished material bin and by an inside-exhausting Steel Craft model FIL2RX nuisance dust collector which controls the fugitive air contaminant emissions generated inside the mill enclosure.

**SECTION D. Source Level Requirements**

Source ID: P305

Source Name: #4 DRYER

Source Capacity/Throughput:

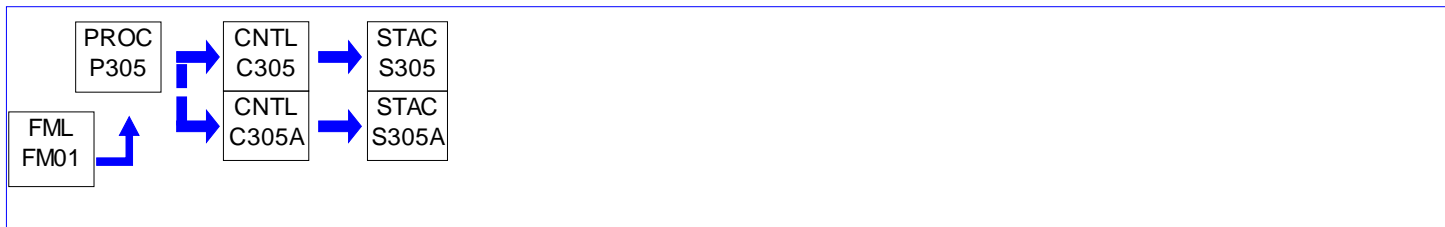
**I. RESTRICTIONS.****Emission Restriction(s).****# 001 [25 Pa. Code §123.13]****Processes**

The permittee shall not permit the emission of particulate matter into the outdoor atmosphere from Source P305 in such a manner that the concentration of particulate matter in the exhaust from Control Device C305 or Control Device C305A exceeds 0.04 grains per dry standard cubic foot of effluent gas volume.

002 [25 Pa. Code §123.21]**General**

The permittee may not permit the emission of sulfur oxides, expressed as SO₂, into the outdoor atmosphere from Source P305 in such a manner that the concentration of the sulfur oxides in the exhaust from Control Device C305 exceeds 500 parts per million, by volume, dry basis.

Fuel Restriction(s).**# 003 [25 Pa. Code §127.441]****Operating permit terms and conditions.**

The rotary dryer incorporated in Source P305 shall only be fired on natural gas.

Operation Hours Restriction(s).**# 004 [25 Pa. Code §127.441]****Operating permit terms and conditions.**

The rotary dryer incorporated in Source P305 shall not be operated more than 4,192 hours in any 12 consecutive month period.

Throughput Restriction(s).**# 005 [25 Pa. Code §127.441]****Operating permit terms and conditions.**

The rotary dryer incorporated in Source P305 shall not process more than 55,296 tons of material in any 12 consecutive month period.

II. TESTING REQUIREMENTS.

No additional testing requirements exist except as provided in other sections of this permit including Section B (State Only General Requirements).

III. MONITORING REQUIREMENTS.**# 006 [25 Pa. Code §127.441]****Operating permit terms and conditions.**

[Additional authority for this permit condition is derived from 25 Pa. Code Sections 127.1 and 127.12]

Control Device C305 shall be equipped with instrumentation to continuously monitor the inlet temperature of the fabric

**SECTION D. Source Level Requirements**

collector.

007 [25 Pa. Code §127.441]**Operating permit terms and conditions.**

[Additional authority for this permit condition is derived from 25 Pa. Code Sections 127.1 and 127.12 and from the Consent Order & Agreement entered into on August 18, 2005, by and between the Department and Keystone Filler & Mfg. Co.]

Control Device C305 and Control Device C305A shall each be equipped with instrumentation to continuously monitor the differential pressure across the respective collector.

IV. RECORDKEEPING REQUIREMENTS.**# 008 [25 Pa. Code §127.441]****Operating permit terms and conditions.**

The permittee shall maintain accurate and comprehensive records of the following:

- (a) The number of hours the dryer incorporated in Source P305 is operated each month.
- (b) The amount of material processed through the dryer incorporated in Source P305 each month.

All records generated pursuant to this condition shall be retained on site for a period of at least five (5) years from the date of generation and shall be provided to the Department upon request.

V. REPORTING REQUIREMENTS.**# 009 [25 Pa. Code §127.441]****Operating permit terms and conditions.**

The permittee shall submit the following records to the Department on a quarterly basis:

- (a) The number of hours the dryer incorporated in Source P305 is operated each month during the respective calendar quarter.
- (b) The amount of material processed through the dryer incorporated in Source P305 each month during the respective calendar quarter.

The quarterly reports shall be submitted to the Department by no later than May 1 for the preceding January 1 to March 31 time period, August 1 for the preceding April 1 to June 30 time period, October 1 for the preceding July 1 to September 30 time period and February 1 for the preceding October 1 to December 31 time period.

VI. WORK PRACTICE REQUIREMENTS.**# 010 [25 Pa. Code §127.441]****Operating permit terms and conditions.**

[Additional authority for this permit condition is derived from 25 Pa. Code Sections 127.1 and 127.12]

The inlet temperature of Control Device C305 shall not exceed 425° F.

011 [25 Pa. Code §127.441]**Operating permit terms and conditions.**

[Additional authority for this permit condition is derived from 25 Pa. Code Sections 127.1 and 127.12]

The leather straps hanging from the truck load out spout incorporated in Source P305 shall not at any time be tucked under the edge of the spout when the spout is being used to load a truck.

012 [25 Pa. Code §127.441]**Operating permit terms and conditions.**

[Additional authority for this permit condition is derived from 25 Pa. Code Sections 127.1 and 127.12]

**SECTION D. Source Level Requirements**

The truck load out spout incorporated in Source P305 shall be extended to the drum top when the spout is being used to load a drum.

013 [25 Pa. Code §127.441]**Operating permit terms and conditions.**

[Additional authority for this permit condition is derived from 25 Pa. Code Sections 127.1 and 127.12]

The rotex screen incorporated in Source P305 shall be fully enclosed when in use.

014 [25 Pa. Code §127.441]**Operating permit terms and conditions.**

[Additional authority for this permit condition is derived from 25 Pa. Code Sections 127.1 and 127.12]

The storage and handling of the material collected in Control Device C305 and Control Device C305A shall not at any time result in the emission of fugitive air contaminants in excess of the limitations specified in 25 Pa. Code Section 123.1.

015 [25 Pa. Code §127.441]**Operating permit terms and conditions.**

[Additional authority for this permit condition is derived from 25 Pa. Code Sections 127.1 and 127.12]

The compressed air system(s) associated with Control Device C305 and Control Device C305A shall be equipped with an air dryer and an oil trap.

016 [25 Pa. Code §127.441]**Operating permit terms and conditions.**

[Additional authority for this permit condition is derived from 25 Pa. Code Sections 127.1 and 127.12]

The permittee shall keep on hand a sufficient quantity of spare fabric collector bags for Control Device C305 and Device C305A in order to be able to immediately replace any bags requiring replacement due to deterioration resulting from routine operation of Source P305 and Control Device C305 or Control Device C305A.

VII. ADDITIONAL REQUIREMENTS.**# 017 [25 Pa. Code §127.441]****Operating permit terms and conditions.**

[Additional authority for this permit condition is derived from 25 Pa. Code Sections 127.1 and 127.12]

Source P305 is the #4 Dryer Operation comprised of the following air contamination sources:

- (a) feed bin
- (b) wet material feed belt to dryer
- (c) 12 ton per hour, natural gas-fired Hardinge model XA14, 7½'x 55' rotary coal dryer equipped with a 4.0 million Btu per hour Webster Engineering model JB3G-50 burner
- (d) 13"x 48"x 45' bucket elevator
- (e) Rotex model 804A screen (and spare)
- (f) screen oversize bin
- (g) truck load out spout (DCL chute)
- (h) 12" screw conveyor located under screen (feeds material from screen to screw conveyor identified in subsection (i))
- (i) 12" screw conveyor (is fed by screw conveyor identified in subsection (h) and transports material to either the bucket elevator which feeds the #6 and #7 storage silos associated with Source P307 or the rail car load out associated with Source P307)
- (j) 12" screw conveyor located under Mikropul collector (feeds material from Mikropul hopper to feed back screw conveyor identified in subsection (k))
- (k) 12" feed back screw conveyor (feeds material from screw conveyor identified in subsection (j) to discharge of the Hardinge dryer/bucket elevator)
- (l) Roots model 418 RCSJH vacuum blower (feeds material to the Hardinge dryer)

**SECTION D. Source Level Requirements**

(m) pneumatic conveying system and associated Tuthill model #2520-J88 blower (feeds material to the Hardinge dryer)

The air contaminant emissions from Source P305 shall be controlled by a Mikropul model 400S-TRH-10 reverse pulse fabric collector (Control Device C305) with pickup points located at the rotary dryer, the bucket elevator, the screen, the oversize bin, the truck load out spout and the feed back screw identified in subsection (k) and by a Mac model 96 FRB 21 reverse pulse receiver (Control Device C305A) with a pickup point located at the Roots vacuum blower.

**SECTION D. Source Level Requirements**

Source ID: P306

Source Name: #5 DRYER

Source Capacity/Throughput:

**I. RESTRICTIONS.****Emission Restriction(s).****# 001 [25 Pa. Code §123.21]****General**

The permittee may not permit the emission of sulfur oxides, expressed as SO₂, into the outdoor atmosphere from Source P306 in such a manner that the concentration of the sulfur oxides in the exhaust from Control Device C306 exceeds 500 parts per million, by volume, dry basis.

002 [25 Pa. Code §127.441]**Operating permit terms and conditions.**

[Additional authority for this permit condition is derived from 25 Pa. Code Sections 127.1 and 127.12]

The emission of nitrogen oxides (NO_x, expressed as NO₂), carbon monoxide and total hydrocarbons from the rotary dryer incorporated in Source P306 shall not exceed 0.10 pounds per million Btu of heat input, 0.01 pounds per million Btu of heat input and 0.016 pounds per million Btu of heat input, respectively.

003 [25 Pa. Code §127.441]**Operating permit terms and conditions.**

[Additional authority for this permit condition is derived from 25 Pa. Code Sections 127.1 and 127.12]

The emission of nitrogen oxides (NO_x, expressed as NO₂), carbon monoxide and total hydrocarbons from the rotary dryer incorporated in Source P306 shall not exceed 0.84 tons, 0.09 tons and 0.14 tons, respectively, in any 12 consecutive month period.

004 [25 Pa. Code §127.441]**Operating permit terms and conditions.**

[Additional authority for this permit condition is derived from 25 Pa. Code Sections 127.1 and 127.12]

The permittee shall not permit the emission of particulate matter into the outdoor atmosphere from the rotary dryer incorporated in Source P306 in such a manner that the concentration of particulate matter in the exhaust from Control Device C306 exceeds 0.01 grains per dry standard cubic foot of effluent gas volume (including particulate matter with an aerodynamic diameter of 10 microns or less, also known as PM-10) The particulate matter emissions from Control Device C306 shall not exceed 1.65 pounds per hour or 3.47 tons in any 12 consecutive month period (including particulate matter with an aerodynamic diameter of 10 microns or less, also known as PM-10).

Compliance with this condition also ensures compliance with 25 Pa. Code Section 123.13.

005 [25 Pa. Code §127.441]**Operating permit terms and conditions.**

[Additional authority for this permit condition is derived from 25 Pa. Code Sections 127.1 and 127.12]

The Mikropul model 64S-10-64 fabric collector incorporated in Source P306 shall not be exhausted directly to atmosphere without prior Department approval and, if approval is granted, shall be subject to a particulate matter emission limitation of 0.01 grains per dry standard cubic foot of effluent gas volume (including particulate matter with an aerodynamic diameter of 10 microns or less, also known as PM-10).

**SECTION D. Source Level Requirements**

Compliance with this condition also ensures compliance with 25 Pa. Code Section 123.13.

Fuel Restriction(s).

006 [25 Pa. Code §127.441]

Operating permit terms and conditions.

[Additional authority for this permit condition is derived from 25 Pa. Code Sections 127.1 and 127.12]

The rotary dryer incorporated in Source P306 shall only be fired on natural gas.

Operation Hours Restriction(s).

007 [25 Pa. Code §127.441]

Operating permit terms and conditions.

[Additional authority for this permit condition is derived from 25 Pa. Code Sections 127.1 and 127.12]

The rotary dryer incorporated in Source P306 shall not be operated more than 4,192 hours in any 12 consecutive month period.

Throughput Restriction(s).

008 [25 Pa. Code §127.441]

Operating permit terms and conditions.

[Additional authority for this permit condition is derived from 25 Pa. Code Sections 127.1 and 127.12]

The rotary dryer incorporated in Source P306 shall not process more than 50,304 tons of material in any 12 consecutive month period.

II. TESTING REQUIREMENTS.

No additional testing requirements exist except as provided in other sections of this permit including Section B (State Only General Requirements).

III. MONITORING REQUIREMENTS.

009 [25 Pa. Code §127.441]

Operating permit terms and conditions.

[Additional authority for this permit condition is derived from 25 Pa. Code Sections 127.1 and 127.12]

Control Device C306 shall be equipped with instrumentation to continuously monitor the inlet temperature of the fabric collector.

010 [25 Pa. Code §127.441]

Operating permit terms and conditions.

[Additional authority for this permit condition is derived from 25 Pa. Code Sections 127.1 and 127.12]

Control Device C306 shall be equipped with an interlock to shut down the burner of the rotary dryer incorporated in Source P306 should the inlet temperature of the fabric collector exceed 300° F.

011 [25 Pa. Code §127.441]

Operating permit terms and conditions.

[Additional authority for this permit condition is derived from 25 Pa. Code Sections 127.1 and 127.12]

Control Device C306 and the Mikropul model 64S-10-64 fabric collector shall each be equipped with instrumentation to

**SECTION D. Source Level Requirements**

continuously monitor the differential pressure across the respective collector.

IV. RECORDKEEPING REQUIREMENTS.

012 [25 Pa. Code §127.441]

Operating permit terms and conditions.

The permittee shall maintain accurate and comprehensive records of the following:

- (a) The number of hours the dryer incorporated in Source P306 is operated each month.
- (b) The amount of material processed through the dryer incorporated in Source P306 each month.

All records generated pursuant to this condition shall be retained on site for a period of at least five (5) years from the date of generation and shall be provided to the Department upon request.

V. REPORTING REQUIREMENTS.

013 [25 Pa. Code §127.441]

Operating permit terms and conditions.

The permittee shall submit the following records to the Department on a quarterly basis:

- (a) The number of hours the dryer incorporated in Source P306 is operated each month during the respective calendar quarter.
- (b) The amount of material processed through the dryer incorporated in Source P306 each month during the respective calendar quarter.

The quarterly reports shall be submitted to the Department by no later than May 1 for the preceding January 1 to March 31 time period, August 1 for the preceding April 1 to June 30 time period, October 1 for the preceding July 1 to September 30 time period and February 1 for the preceding October 1 to December 31 time period.

VI. WORK PRACTICE REQUIREMENTS.

014 [25 Pa. Code §127.441]

Operating permit terms and conditions.

[Additional authority for this permit condition is derived from 25 Pa. Code Sections 127.1 and 127.12]

The rotary dryer incorporated in Source P306 shall only be used to dry anthracite coal, semi-anthracite coal and bituminous coal.

015 [25 Pa. Code §127.441]

Operating permit terms and conditions.

[Additional authority for this permit condition is derived from 25 Pa. Code Sections 127.1 and 127.12]

The screen, bucket elevator and reject container incorporated in Source P306 shall each be completely enclosed except for points of entry and fabric collector dust capture pickup points.

016 [25 Pa. Code §127.441]

Operating permit terms and conditions.

[Additional authority for this permit condition is derived from 25 Pa. Code Sections 127.1 and 127.12]

There shall be no visible fugitive air contaminant emissions from the feed bin and feed conveyor incorporated in Source P306, from the bulk truck and bulk railcar load outs incorporated in Source P306 or from the building which houses the rotary dryer incorporated in Source P306.

**SECTION D. Source Level Requirements****# 017 [25 Pa. Code §127.441]****Operating permit terms and conditions.**

[Additional authority for this permit condition is derived from 25 Pa. Code Sections 127.1 and 127.12]

The bulk railcar load out incorporated in Source P306 shall incorporate a cap or cover that completely covers the loading hatch through which loading is occurring and a capture hood located over the cap or cover. Both the cap or cover and the capture hood shall be ducted to Control Device C306. At no time shall open-topped railcars be loaded nor shall any loading hatch other than the one through which loading is occurring be open to atmosphere nor shall any railcar with a loading hatch larger than the cap or cover ever be loaded.

018 [25 Pa. Code §127.441]**Operating permit terms and conditions.**

[Additional authority for this permit condition is derived from 25 Pa. Code Sections 127.1 and 127.12]

The bulk truck load out incorporated in Source P306 shall only be used to load enclosed bulk material handling or tanker trucks. It shall not be used to load open-topped trucks at any time. The bulk truck load out shall incorporate a cap or cover that completely covers the loading hatch through which loading is occurring. The cap or cover shall be ducted to Control Device C306. At no time shall any loading hatch other than the one through which loading is occurring be open to atmosphere nor shall any truck with a loading hatch larger than the cap or cover ever be loaded.

019 [25 Pa. Code §127.441]**Operating permit terms and conditions.**

[Additional authority for this permit condition is derived from 25 Pa. Code Sections 127.1 and 127.12]

The bulk railcar and bulk truck load out incorporated in Source P306 shall be located within a roofed structure which incorporates a curtain that completely surrounds all sides of the structure not directly adjacent to the building which houses the rotary dryer incorporated in Source P306. The curtain shall extend from the roof of the structure to the top of the railcar and/or truck and shall be kept in good repair at all times.

020 [25 Pa. Code §127.441]**Operating permit terms and conditions.**

[Additional authority for this permit condition is derived from 25 Pa. Code Sections 127.1 and 127.12]

The permittee shall keep on hand a sufficient quantity of spare fabric collector bags for Control Device C306 and the Mikropul model 64S-10-64 fabric collector in order to be able to immediately replace any bags requiring replacement due to deterioration resulting from routine operation of Source P306 and Control Device C306 or Mikropul model 64S-10-64 fabric collector.

021 [25 Pa. Code §127.441]**Operating permit terms and conditions.**

[Additional authority for this permit condition is derived from 25 Pa. Code Sections 127.1 and 127.12]

The storage and handling of the material collected in Control Device C305 and the Mikropul model 64S-10-64 fabric collector shall not at any time result in the emission of fugitive air contaminants in excess of the limitations specified in 25 Pa. Code Section 123.1.

022 [25 Pa. Code §127.441]**Operating permit terms and conditions.**

[Additional authority for this permit condition is derived from 25 Pa. Code Sections 127.1 and 127.12]

The compressed air system(s) associated with Control Device C305 and the Mikropul model 64S-10-64 fabric collector shall be equipped with an air dryer and an oil trap.

**SECTION D. Source Level Requirements****VII. ADDITIONAL REQUIREMENTS.****# 023 [25 Pa. Code §127.441]****Operating permit terms and conditions.**

[Additional authority for this permit condition is derived from 25 Pa. Code Sections 127.1 and 127.12]

Source P306 is the #5 Dryer Operation comprised of the following air contamination sources:

- (a) feed bin
- (b) 12 ton per hour, natural gas-fired CMI Corporation model 736-157 rotary coal dryer equipped with a 4.0 million Btu per hour Webster Engineering model JB2G-20 burner
- (c) 30" belt conveyor
- (d) Gough Econ model TRS 8-3 twin rotary screen
- (e) 4'x 4' reject storage container
- (f) bucket elevator
- (g) two 12" screw conveyors((1) feeds material from bucket elevator to screw conveyor for load outs and supersacker and (2) feeds material from screw conveyor to either the railcar load out, the truck load out or the supersacker)
- (h) railcar load out spout/hood
- (i) truck load out spout
- (j) Taylor supersacker

The air contaminant emissions from Source P306 shall be controlled by a Mikropul model 400S-TRH-10 reverse pulse fabric collector (Control Device C306) with pickup points located at the rotary dryer, the railcar load out spout/hood and the truck load out spout and by an inside-exhausting Mikropul model 64S-10-64 reverse pulse fabric collector with pickup points located at the rotary screen, the reject container and the bucket elevator.

The air contaminant emissions from the supersacker incorporated in Source P306 shall be controlled by the Flex Kleen model 100-WRT-160 fabric collector (Control Device C307A) associated with Source P307.

**SECTION D. Source Level Requirements**

Source ID: P307

Source Name: MATERIAL STORAGE OPERATION

Source Capacity/Throughput:

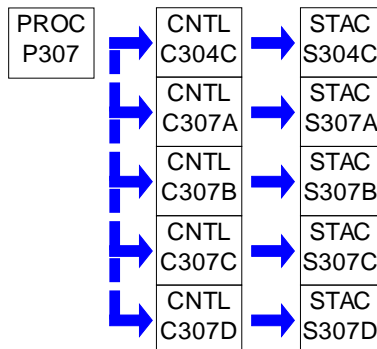
**I. RESTRICTIONS.****Emission Restriction(s).**

001 [25 Pa. Code §123.13]

Processes

[Additional authority for this permit condition is also derived from 25 Pa. Code Sections 127.1 and 127.12]

The permittee shall not permit the emission of particulate matter into the outdoor atmosphere from Source P307 in such a manner that the concentration of particulate matter in the exhaust from Control Device C307A, Control Device C307B, Control Device C307C or Control Device C307D exceeds 0.04 grains per dry standard cubic foot of effluent gas volume.

II. TESTING REQUIREMENTS.

No additional testing requirements exist except as provided in other sections of this permit including Section B (State Only General Requirements).

III. MONITORING REQUIREMENTS.

002 [25 Pa. Code §127.441]

Operating permit terms and conditions.

[Additional authority for this permit condition is derived from 25 Pa. Code Sections 127.1 and 127.12 and from the Consent Order & Agreement entered into on August 18, 2005, by and between the Department and Keystone Filler & Mfg. Co.]

Control Device C307A, Control Device C307B, Control Device C307C and Control Device C307D shall each be equipped with instrumentation to continuously monitor the differential pressure across the respective collector.

IV. RECORDKEEPING REQUIREMENTS.

No additional record keeping requirements exist except as provided in other sections of this permit including Section B (State Only General Requirements).

V. REPORTING REQUIREMENTS.

No additional reporting requirements exist except as provided in other sections of this permit including Section B (State Only General Requirements).

**SECTION D. Source Level Requirements****VI. WORK PRACTICE REQUIREMENTS.****# 003 [25 Pa. Code §127.441]****Operating permit terms and conditions.**

[Additional authority for this permit condition is derived from 25 Pa. Code Sections 127.1 and 127.12]

The air contaminant emissions within the air space above the bulk railcar load out spout incorporated in Source P307 shall be controlled by a 8 foot long by 8 foot wide hood equipped with 12 foot long vertically-oriented plastic strips along the entire perimeter of the hood and ducted to Control Device C304C. The respective hood shall be ducted to Control Device C304C, the plastic strips shall be hanging vertically in place and Control Device C304C shall be operating at all times that loading operations are occurring at the bulk railcar load out spout incorporated in Source P307.

004 [25 Pa. Code §127.441]**Operating permit terms and conditions.**

[Additional authority for this permit condition is derived from 25 Pa. Code Sections 127.1 and 127.12]

The bulk railcar load out spout incorporated in Source P307 shall not be simultaneously operated with the railcar load out spout incorporated in Source P304. When the bulk railcar load out spout incorporated in Source P307 is being used, the ductwork from the railcar load out spout incorporated in Source P304 shall be closed off. When the railcar load out spout incorporated in Source P304 is being used, the ductwork from the bulk railcar load out spout incorporated in Source P307 shall be closed off.

005 [25 Pa. Code §127.441]**Operating permit terms and conditions.**

[Additional authority for this permit condition is derived from 25 Pa. Code Sections 127.1 and 127.12]

Control Device C307A shall be used to control the air contaminant emissions from either the exhaust header for the #3 and #4 storage silos incorporated in Source P307 or the exhaust header for the screw conveyor, the bulk railcar load out, the bucket elevator, the #6 and #7 storage silos, the #6 and #7 storage silo truck load outs and the Taylor bag filler incorporated in Source P306. It shall never be used to simultaneously control the air contaminant emissions from both exhaust headers.

006 [25 Pa. Code §127.441]**Operating permit terms and conditions.**

[Additional authority for this permit condition is derived from 25 Pa. Code Sections 127.1 and 127.12]

The permittee shall keep on hand a sufficient quantity of spare fabric collector bags for Control Device C307A and cartridge filters for Control Device C307B, Control Device C307C and Control Device C307D in order to be able to immediately replace any bags or filters requiring replacement due to deterioration resulting from routine operation of Source P307 and Control Device C307A, Control Device C307B, Control Device C307C or Control Device C307D.

007 [25 Pa. Code §127.441]**Operating permit terms and conditions.**

[Additional authority for this permit condition is derived from 25 Pa. Code Sections 127.1 and 127.12]

The storage and handling of the material collected in Control Device C307A, Control Device C307B, Control Device C307C and Control Device C307D shall not at any time result in the emission of fugitive air contaminants in excess of the limitations specified in 25 Pa. Code Section 123.1.

VII. ADDITIONAL REQUIREMENTS.**# 008 [25 Pa. Code §127.441]****Operating permit terms and conditions.**

[Additional authority for this permit condition is derived from 25 Pa. Code Sections 127.1 and 127.12]

Source P307 is a Material Storage Operation comprised of the following air contamination sources:

- (a) #1 storage silo
- (b) #3 storage silo

**SECTION D. Source Level Requirements**

- (c) #4 storage silo
- (d) #6 storage silo and associated truck load out spout
- (e) #7 storage silo and associated truck load out spout
- (f) bucket elevator
- (g) bulk railcar load out spout and 8'x 8' hood
- (h) 9" screw conveyor (feeds material from #1 storage silo to the Raymond mill associated with the #2 Mill (Source P304))

The air contaminant emissions from Source P307 shall be controlled by a Flex Kleen model 100 WRT 160 reverse pulse fabric collector (Control Device C307A) with pickup points located at the #3 storage silo, the #4 storage silo, the #6 storage silo, the #6 silo truck load out spout, the #7 storage silo, the #7 silo truck load out spout, the bucket elevator, the screw conveyor and the bulk railcar load out spout, as well as the Taylor supersacker associated with the #5 Dryer (Source P306), by a Dynamic Air model 400-343 cartridge collector (Control Device C307B) with a pickup point located at the #1 storage silo, by a Dynamic Air model 400-343 cartridge collector (Control Device C307C) with a pickup point located at the #4 storage silo and by a Dynamic Air model 400-343 cartridge collector (Control Device C307D) with a pickup point located at the #7 storage silo.

The air contaminant emissions from the 8'x 8' bulk railcar load out hood incorporated in Source P307 shall be controlled by the Griffin model JA 200 SA fabric collector (Control Device C304C) associated with Source P304.

**SECTION D. Source Level Requirements**

Source ID: P308

Source Name: CEDAR RAPIDS PORTABLE CRUSHING PLANT

Source Capacity/Throughput:

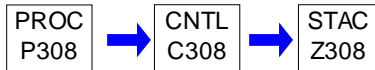
**I. RESTRICTIONS.**

No additional requirements exist except as provided in other sections of this permit including Section B (State Only General Requirements).

II. TESTING REQUIREMENTS.

No additional testing requirements exist except as provided in other sections of this permit including Section B (State Only General Requirements).

III. MONITORING REQUIREMENTS.

No additional monitoring requirements exist except as provided in other sections of this permit including Section B (State Only General Requirements).

IV. RECORDKEEPING REQUIREMENTS.

No additional record keeping requirements exist except as provided in other sections of this permit including Section B (State Only General Requirements).

V. REPORTING REQUIREMENTS.

No additional reporting requirements exist except as provided in other sections of this permit including Section B (State Only General Requirements).

VI. WORK PRACTICE REQUIREMENTS.**# 001 [25 Pa. Code §127.441]****Operating permit terms and conditions.**

[Additional authority for this permit condition is derived from 25 Pa. Code Sections 127.1 and 127.12]

Control Device C308 shall be connected to an on-demand water source capable of delivering an adequate supply of water any time Source P308 is in operation, including winter. On-demand shall be interpreted as meaning that water can be provided to the spray system at any time with no more effort than turning a valve.

002 [25 Pa. Code §127.441]**Operating permit terms and conditions.**

[Additional authority for this permit condition is derived from 25 Pa. Code Sections 127.1 and 127.12]

The permittee shall post truck tarping instructions in appropriate areas, as well as make appropriate follow-up to assure that trucks are properly covered to avoid fugitive emissions.

003 [25 Pa. Code §127.441]**Operating permit terms and conditions.**

[Additional authority for this permit condition is derived from 25 Pa. Code Sections 127.1 and 127.12]

The use of any roadways and/or any material stockpiling operations associated with Source P308 shall not result in the emission of fugitive particulate matter in excess of the limitation specified in 25 Pa. Code Section 123.2. All roadways shall be swept as needed to prevent the emission of fugitive particulate matter.

**SECTION D. Source Level Requirements****VII. ADDITIONAL REQUIREMENTS.****# 004 [25 Pa. Code §127.441]****Operating permit terms and conditions.**

[Additional authority for this permit condition is derived from 25 Pa. Code Sections 127.1 and 127.12]

Source P308 is a portable coal, shale and rottenstone crushing plant comprised of the following air contamination sources:

- (a) 20 ton per hour Cedar Rapids model #4033 hammermill crusher
- (b) 10 ton feed bin
- (c) 48"x 18" Eriez vibrating feeder
- (d) 24"x 20' Medco belt conveyor

The fugitive particulate matter emissions from Source P308 shall be controlled by a water spray dust suppression system (Control Device C308).

**SECTION D. Source Level Requirements**

Source ID: P309

Source Name: KOLMAN PORTABLE SCREENING PLANT

Source Capacity/Throughput:

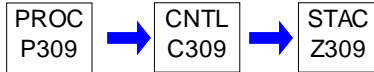
**I. RESTRICTIONS.**

No additional requirements exist except as provided in other sections of this permit including Section B (State Only General Requirements).

II. TESTING REQUIREMENTS.

No additional testing requirements exist except as provided in other sections of this permit including Section B (State Only General Requirements).

III. MONITORING REQUIREMENTS.

No additional monitoring requirements exist except as provided in other sections of this permit including Section B (State Only General Requirements).

IV. RECORDKEEPING REQUIREMENTS.

No additional record keeping requirements exist except as provided in other sections of this permit including Section B (State Only General Requirements).

V. REPORTING REQUIREMENTS.

No additional reporting requirements exist except as provided in other sections of this permit including Section B (State Only General Requirements).

VI. WORK PRACTICE REQUIREMENTS.**# 001 [25 Pa. Code §127.441]****Operating permit terms and conditions.**

[Additional authority for this permit condition is derived from 25 Pa. Code Sections 127.1 and 127.12]

The permittee shall post truck tarping instructions in appropriate areas, as well as make appropriate follow-up to assure that trucks are properly covered to avoid fugitive emissions.

002 [25 Pa. Code §127.441]**Operating permit terms and conditions.**

[Additional authority for this permit condition is derived from 25 Pa. Code Sections 127.1 and 127.12]

The use of any roadways and/or any material stockpiling operations associated with Source P309 shall not result in the emission of fugitive particulate matter in excess of the limitation specified in 25 Pa. Code Section 123.2. All roadways shall be swept as needed to prevent the emission of fugitive particulate matter.

003 [25 Pa. Code §127.441]**Operating permit terms and conditions.**

[Additional authority for this permit condition is derived from 25 Pa. Code Sections 127.1 and 127.12]

Control Device P309 shall be connected to an on-demand water source capable of delivering an adequate supply of water any time Source P309 is in operation, including winter. On-demand shall be interpreted as meaning that water can be provided to the spray system at any time with no more effort than turning a valve.

**SECTION D. Source Level Requirements****VII. ADDITIONAL REQUIREMENTS.****# 004 [25 Pa. Code §127.441]****Operating permit terms and conditions.**

[Additional authority for this permit condition is derived from 25 Pa. Code Sections 127.1 and 127.12]

Source P309 is a Kolman model 101XHD portable coal, shale and rottenstone screening plant comprised of the following air contamination sources:

- (a) 5'x 10' double deck screen
- (b) feed hopper
- (c) 36" belt conveyor

The fugitive particulate matter emissions from Source P309 shall be controlled by a water spray dust suppression system (Control Device C309).

**SECTION D. Source Level Requirements**

Source ID: P310

Source Name: TESAB PORTABLE CRUSHING PLANT

Source Capacity/Throughput:

**I. RESTRICTIONS.****Emission Restriction(s).****# 001 [25 Pa. Code §123.13]****Processes**

[Additional authority for this permit condition is derived from 25 Pa. Code Sections 127.1 and 127.12]

The permittee shall not permit the emission of particulate matter into the outdoor atmosphere from the 200 horsepower Caterpillar model 3306TA diesel engine incorporated in Source P310 in such a manner that the concentration of particulate matter in the exhaust exceeds 0.04 grains per dry standard cubic foot of effluent gas volume.

002 [25 Pa. Code §123.21]**General**

[Additional authority for this permit condition is derived from 25 Pa. Code Sections 127.1 and 127.12]

The permittee shall not permit the emission of sulfur oxides into the outdoor atmosphere from the 200 horsepower Caterpillar model 3306TA diesel engine incorporated in Source P310 in such a manner that the concentration of sulfur oxides, expressed as sulfur dioxide (SO₂), in the exhaust exceeds 500 parts per million, by volume, dry basis.

003 [25 Pa. Code §127.441]**Operating permit terms and conditions.**

[Additional authority for this permit condition is derived from 25 Pa. Code Sections 127.1 and 127.12]

The air contaminant emissions from the 200 horsepower Caterpillar model 3306TA diesel engine incorporated in Source P310 shall not exceed the following limitations:

- (a) Nitrogen Oxides, expressed as nitrogen dioxide (NO₂) - 6.85 grams per horsepower hour, 3.02 pounds per hour and 3.14 tons in any 12-consecutive month period.
- (b) Carbon Monoxide - 2.0 grams per horsepower hour, 0.89 pounds per hour and 0.93 tons in any 12-consecutive month period.
- (c) Total Hydrocarbons - 0.97 grams per horsepower hour, 0.43 pounds per hour and 0.45 tons in any 12-consecutive month period.
- (d) Particulate Matter - 0.4 grams per horsepower hour, 0.18 pounds per hour and 0.19 tons in any 12-consecutive month period.

004 [25 Pa. Code §127.441]**Operating permit terms and conditions.**

[Additional authority for this permit condition is derived from 25 Pa. Code Sections 127.1 and 127.12]

No visible fugitive emissions shall occur from Source P310.

005 [25 Pa. Code §127.441]**Operating permit terms and conditions.**

[Additional authority for this permit condition is derived from 25 Pa. Code Sections 127.1 and 127.12]

The visible emissions from the 200 horsepower Caterpillar model 3306TA diesel engine incorporated in Source P310 shall not be equal to or greater than 10% opacity for a period or periods aggregating more than 3 minutes in any 1 hour or be

**SECTION D. Source Level Requirements**

equal to or greater than 30% at any time.

Compliance with this condition also ensures compliance with 25 Pa. Code Section 123.41.

Fuel Restriction(s).

006 [25 Pa. Code §127.441]

Operating permit terms and conditions.

[Additional authority for this permit condition is derived from 25 Pa. Code Sections 127.1 and 127.12]

The sulfur content of the diesel fuel used in the 200 horsepower Caterpillar model 3306TA diesel engine incorporated in Source P310 shall not exceed 0.3%, by weight.

Operation Hours Restriction(s).

007 [25 Pa. Code §127.441]

Operating permit terms and conditions.

[Additional authority for this permit condition is derived from 25 Pa. Code Sections 127.1 and 127.12]

Neither the Tesab model RK623 Rotocrusher nor the 200 horsepower Caterpillar model 3306TA diesel engine incorporated in Source P310 shall be operated on site more than 2,080 hours in any 12 consecutive month period.

II. TESTING REQUIREMENTS.

No additional testing requirements exist except as provided in other sections of this permit including Section B (State Only General Requirements).

III. MONITORING REQUIREMENTS.

No additional monitoring requirements exist except as provided in other sections of this permit including Section B (State Only General Requirements).

IV. RECORDKEEPING REQUIREMENTS.

008 [25 Pa. Code §127.441]

Operating permit terms and conditions.

The permittee shall maintain accurate and comprehensive records of the following:

- (a) Total number of hours the Tesab model RK623 Rotocrusher incorporated in Source P310 is operated each month.
- (b) Total number of hours the 200 horsepower Caterpillar model 3306TA diesel engine incorporated in Source P310 is operated each month.

All records generated pursuant to this condition shall be retained on site for a period of at least five (5) years from the date of generation and shall be provided to the Department upon request.

V. REPORTING REQUIREMENTS.

009 [25 Pa. Code §127.441]

Operating permit terms and conditions.

The permittee shall submit the following records to the Department on a quarterly basis:

- (a) The number of hours the Tesab model RK623 Rotocrusher incorporated in Source P310 is operated each month during the respective calendar quarter.
- (b) The number of hours the 200 horsepower Caterpillar model 3306TA diesel engine incorporated in Source P310 is operated each month during the respective calendar quarter.

**SECTION D. Source Level Requirements**

The quarterly reports shall be submitted to the Department by no later than May 1 for the preceding January 1 to March 31 time period, August 1 for the preceding April 1 to June 30 time period, October 1 for the preceding July 1 to September 30 time period and February 1 for the preceding October 1 to December 31 time period.

VI. WORK PRACTICE REQUIREMENTS.

010 [25 Pa. Code §127.441]

Operating permit terms and conditions.

[Additional authority for this permit condition is derived from 25 Pa. Code Sections 127.1 and 127.12]

Source P310 shall not be used to process metallic minerals.

011 [25 Pa. Code §127.441]

Operating permit terms and conditions.

[Additional authority for this permit condition is derived from 25 Pa. Code Sections 127.1 and 127.12]

Control Device C310 shall be connected to an on demand water source capable of delivering an adequate supply of water any time Source P310 is in operation, including winter. On-demand shall be interpreted as meaning that water can be provided to the spray system at any time with no more effort than turning a valve.

012 [25 Pa. Code §127.441]

Operating permit terms and conditions.

[Additional authority for this permit condition is derived from 25 Pa. Code Sections 127.1 and 127.12]

The permittee shall post truck tarping instructions in appropriate areas as well as make appropriate follow-up to assure that trucks are properly covered to avoid fugitive emissions.

013 [25 Pa. Code §127.441]

Operating permit terms and conditions.

[Additional authority for this permit condition is derived from 25 Pa. Code Sections 127.1 and 127.12]

The use of any roadways and/or any material stockpiling operations associated with Source P310 shall not result in the emission of fugitive particulate matter in excess of the limitation specified in 25 Pa. Code Section 123.2. All roadways shall be swept as needed to prevent the emission of fugitive particulate matter.

VII. ADDITIONAL REQUIREMENTS.

014 [25 Pa. Code §127.441]

Operating permit terms and conditions.

[Additional authority for this permit condition is derived from 25 Pa. Code Sections 127.1 and 127.12]

Source P310 is a Tesab portable coal, shale and rottenstone crushing plant comprised of the following air contamination sources:

- (a) 100 ton per hour Tesab model RK623 Rotocrusher (impact crusher)
- (b) 8 cubic yard hopper
- (c) 30" feed conveyor
- (d) 26" discharge conveyor
- (e) 200 horsepower Caterpillar model 3306TA lean burn diesel engine equipped with a Caterpillar catalyzed converter/muffler

The fugitive particulate matter emissions from Source P310 shall be controlled by a water spray dust suppression system (Control Device C310) which shall, at a minimum, incorporate four spray nozzles located at the 8 cubic yard hopper.

015 [25 Pa. Code §127.441]

Operating permit terms and conditions.

[Additional authority for this permit condition is derived from 25 Pa. Code Sections 127.1 and 127.12]

**SECTION D. Source Level Requirements**

The 200 horsepower Caterpillar model 3306TA diesel engine incorporated in Source P310 shall be equipped with a Caterpillar® Catalyzed Converter/Muffler (Control Device C310A) to control the emission of carbon monoxide.

**SECTION D. Source Level Requirements**

Source ID: P311

Source Name: EXTEC PORTABLE SCREENING PLANT

Source Capacity/Throughput:

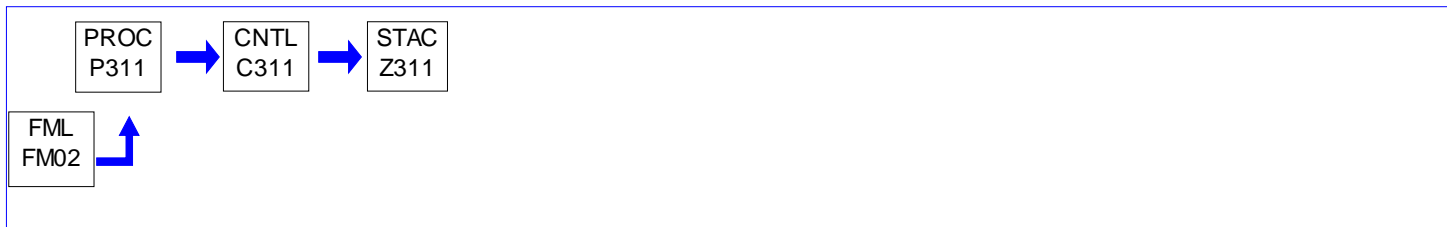
**I. RESTRICTIONS.****Emission Restriction(s).****# 001 [25 Pa. Code §123.13]****Processes**

[Additional authority for this permit condition is derived from 25 Pa. Code Sections 127.1 and 127.12]

The permittee shall not permit the emission of particulate matter into the outdoor atmosphere from the 96 horsepower Deutz model BF4M1012C diesel engine incorporated in Source P311 in such a manner that the concentration of particulate matter in the exhaust exceeds 0.04 grains per dry standard cubic foot of effluent gas volume.

002 [25 Pa. Code §123.21]**General**

[Additional authority for this permit condition is derived from 25 Pa. Code Sections 127.1 and 127.12]

The permittee shall not permit the emission of sulfur oxides into the outdoor atmosphere from the 96 horsepower Deutz model BF4M1012C diesel engine incorporated in Source P311 in such a manner that the concentration of sulfur oxides, expressed as sulfur dioxide (SO₂), in the exhaust exceeds 500 parts per million, by volume, dry basis.

003 [25 Pa. Code §127.441]**Operating permit terms and conditions.**

[Additional authority for this permit condition is derived from 25 Pa. Code Sections 127.1 and 127.12]

The air contaminant emissions from the 96 horsepower Deutz model BF4M1012C diesel engine incorporated in Source P311 shall not exceed the following limitations:

- (a) Nitrogen Oxides, expressed as nitrogen dioxide (NO₂) - 6.5 grams per horsepower hour, 1.38 pounds per hour and 1.44 tons in any 12-consecutive month period.
- (b) Carbon Monoxide - 1.3 grams per horsepower hour, 0.28 pounds per hour and 0.29 tons in any 12-consecutive month period.
- (c) Volatile Organic Compounds - 0.3 grams per horsepower hour, 0.064 pounds per hour and 0.067 tons in any 12-consecutive month period.
- (d) Particulate Matter - 0.1 grams per horsepower hour, 0.021 pounds per hour and 0.022 tons in any 12-consecutive month period.

004 [25 Pa. Code §127.441]**Operating permit terms and conditions.**

[Additional authority for this permit condition is derived from 25 Pa. Code Sections 127.1 and 127.12]

No visible fugitive emissions shall occur from Source P311.

005 [25 Pa. Code §127.441]**Operating permit terms and conditions.**

[Additional authority for this permit condition is derived from 25 Pa. Code Sections 127.1 and 127.12]

The visible emissions from the 96 horsepower Deutz model BF4M1012C diesel engine incorporated in Source P311 shall not be equal to or greater than 10% opacity for a period or periods aggregating more than 3 minutes in any 1 hour or be

**SECTION D. Source Level Requirements**

equal to or greater than 30% at any time.

Compliance with this condition also ensures compliance with 25 Pa. Code Section 123.41.

Fuel Restriction(s).

006 [25 Pa. Code §127.441]

Operating permit terms and conditions.

[Additional authority for this permit condition is derived from 25 Pa. Code Sections 127.1 and 127.12]

The sulfur content of the diesel fuel used in the 96 horsepower Deutz model BF4M1012C diesel engine incorporated in Source P311 shall not exceed 0.3%, by weight.

Operation Hours Restriction(s).

007 [25 Pa. Code §127.441]

Operating permit terms and conditions.

[Additional authority for this permit condition is derived from 25 Pa. Code Sections 127.1 and 127.12]

Neither the Extec S-4 screen nor the associated 96 horsepower Deutz model BF4M1012C diesel engine incorporated in Source P311 shall be operated on site more than 2,080 hours in any 12 consecutive month period.

II. TESTING REQUIREMENTS.

No additional testing requirements exist except as provided in other sections of this permit including Section B (State Only General Requirements).

III. MONITORING REQUIREMENTS.

No additional monitoring requirements exist except as provided in other sections of this permit including Section B (State Only General Requirements).

IV. RECORDKEEPING REQUIREMENTS.

008 [25 Pa. Code §127.441]

Operating permit terms and conditions.

The permittee shall maintain accurate and comprehensive records of the following:

- (a) Total number of hours the Extec S-4 screen incorporated in Source P311 is operated each month.
- (b) Total number of hours the 96 horsepower Deutz model BF4M1012C diesel engine incorporated in Source P311 is operated each month.

All records generated pursuant to this condition shall be retained on site for a period of at least five (5) years from the date of generation and shall be provided to the Department upon request.

V. REPORTING REQUIREMENTS.

009 [25 Pa. Code §127.441]

Operating permit terms and conditions.

The permittee shall submit the following records to the Department on a quarterly basis:

- (a) The number of hours the Extec S-4 screen incorporated in Source P311 is operated each month during the respective calendar quarter.
- (b) The number of hours the 96 horsepower Deutz model BF4M1012C diesel engine incorporated in Source P311 is operated each month during the respective calendar quarter.

**SECTION D. Source Level Requirements**

The quarterly reports shall be submitted to the Department by no later than May 1 for the preceding January 1 to March 31 time period, August 1 for the preceding April 1 to June 30 time period, October 1 for the preceding July 1 to September 30 time period and February 1 for the preceding October 1 to December 31 time period.

VI. WORK PRACTICE REQUIREMENTS.

010 [25 Pa. Code §127.441]

Operating permit terms and conditions.

[Additional authority for this permit condition is derived from 25 Pa. Code Sections 127.1 and 127.12]

Source P311 shall not be used to process metallic minerals.

011 [25 Pa. Code §127.441]

Operating permit terms and conditions.

[Additional authority for this permit condition is derived from 25 Pa. Code Sections 127.1 and 127.12]

Control Device C311 shall be connected to an on demand water source capable of delivering an adequate supply of water any time Source P311 is in operation, including winter. On-demand shall be interpreted as meaning that water can be provided to the spray system at any time with no more effort than turning a valve.

012 [25 Pa. Code §127.441]

Operating permit terms and conditions.

[Additional authority for this permit condition is derived from 25 Pa. Code Sections 127.1 and 127.12]

The permittee shall post truck tarping instructions in appropriate areas as well as make appropriate follow-up to assure that trucks are properly covered to avoid fugitive emissions.

013 [25 Pa. Code §127.441]

Operating permit terms and conditions.

[Additional authority for this permit condition is derived from 25 Pa. Code Sections 127.1 and 127.12]

The use of any roadways and/or any material stockpiling operations associated with Source P311 shall not result in the emission of fugitive particulate matter in excess of the limitation specified in 25 Pa. Code Section 123.2. All roadways shall be swept as needed to prevent the emission of fugitive particulate matter.

VII. ADDITIONAL REQUIREMENTS.

014 [25 Pa. Code §127.441]

Operating permit terms and conditions.

[Additional authority for this permit condition is derived from 25 Pa. Code Sections 127.1 and 127.12]

Source P311 is an Extec portable coal, shale and rottenstone screening plant comprised of the following air contamination sources:

- (a) 56"x56" double deck Extec S-4 screen
- (b) 7 cubic yard hopper
- (c) 38" feed conveyor
- (d) three 28" discharge conveyors
- (e) 96 horsepower Deutz model BF4M1012C lean burn diesel engine

The fugitive particulate matter emissions from Source P311 shall be controlled by a water spray dust suppression system (Control Device C311) which shall, at a minimum, incorporate four spray nozzles at the 7 cubic yard hopper.

**SECTION D. Source Level Requirements**

Source ID: P312

Source Name: PARTS DEGREASER

Source Capacity/Throughput:

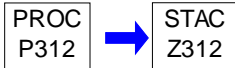
**I. RESTRICTIONS.**

No additional requirements exist except as provided in other sections of this permit including Section B (State Only General Requirements).

II. TESTING REQUIREMENTS.

No additional testing requirements exist except as provided in other sections of this permit including Section B (State Only General Requirements).

III. MONITORING REQUIREMENTS.

No additional monitoring requirements exist except as provided in other sections of this permit including Section B (State Only General Requirements).

IV. RECORDKEEPING REQUIREMENTS.**# 001 [25 Pa. Code §127.441]****Operating permit terms and conditions.**

The permittee shall maintain accurate and comprehensive records of the following:

- (a) The identity and amount of solvent placed into Source P312 each month.
- (b) The identity and amount of spent solvent removed from Source P312 each month.

All records generated pursuant to this condition shall be retained for a minimum of five (5) years and shall be made available to the Department upon request.

002 [25 Pa. Code §129.63]**Degreasing operations**

The permittee shall maintain accurate and comprehensive records of the following:

- (a) The name and address of the supplier of the solvent used in Source P312.
- (b) The type of solvent used in Source P312 including the product or vendor identification number.
- (c) The vapor pressure of the solvent used in Source P312 measured in millimeters of mercury (mm Hg) at 20°C (68°F).

All records generated pursuant to this condition shall be retained at least two (2) years and shall be made available to the Department upon request. An invoice, bill of sale, certificate that corresponds to a number of sales, Material Safety Data Sheet (MSDS), or other appropriate documentation acceptable to the Department may be used to comply with this section.

V. REPORTING REQUIREMENTS.**# 003 [25 Pa. Code §127.441]****Operating permit terms and conditions.**

The permittee shall submit the following records to the Department on a quarterly basis:

- (a) The identity and amount of solvent placed into Source P312 each month during the respective calendar quarter.
- (b) The identity and amount of spent solvent removed from Source P312 each month during the respective calendar quarter.

The quarterly reports shall be submitted to the Department by no later than May 1 for the preceding January 1 to March 31 time period, August 1 for the preceding April 1 to June 30 time period, October 1 for the preceding July 1 to September 30

**SECTION D. Source Level Requirements**

time period and February 1 for the preceding October 1 to December 31 time period.

VI. WORK PRACTICE REQUIREMENTS.

004 [25 Pa. Code §127.441]

Operating permit terms and conditions.

Solvents containing hazardous air pollutants as an intentionally-added ingredient shall not be used in Source P312.

005 [25 Pa. Code §129.63]

Degreasing operations

Source P312 shall have a permanent, conspicuous label summarizing the operating requirements specified in condition #006 herein. In addition, the label shall also list the following discretionary good operating practices:

- (a) Cleaned parts should be drained at least 15 seconds or until dripping ceases, whichever is longer. Parts having cavities or blind holes shall be tipped or rotated while the part is draining. During the draining, tipping or rotating, the parts should be positioned so that solvent drains directly back to the cold cleaning machine.
- (b) When a pump-agitated solvent bath is used, the agitator should be operated to produce a rolling motion of the solvent with no observable splashing of the solvent against the tank walls or the parts being cleaned.
- (c) Work area fans should be located and positioned so that they do not blow across the opening of the degreaser unit.

006 [25 Pa. Code §129.63]

Degreasing operations

Source P312 shall be operated in accordance with the following procedures:

- (a) Waste solvent shall be collected and stored in closed containers. The closed containers may contain a device that allows pressure relief, but does not allow liquid solvent to drain from the container.
- (b) Flushing of parts using a flexible hose or other flushing device shall be performed only within the cold cleaning machine. The solvent spray shall be a solid fluid stream, not an atomized or shower spray.
- (c) Sponges, fabric, wood, leather, paper products and other absorbent materials may not be cleaned in the cold cleaning machine.
- (d) Air agitated solvent baths may not be used.
- (e) Spills during solvent transfer and use of the cold cleaning machine shall be cleaned up immediately.

007 [25 Pa. Code §129.63]

Degreasing operations

Source P312 shall be equipped with a cover(s) that shall be closed at all times except during the cleaning of parts or the addition or removal of solvent. A perforated drain with a diameter of not more than six inches shall be considered an acceptable cover.

008 [25 Pa. Code §129.63]

Degreasing operations

Solvents with a vapor pressure of 1.0 millimeter of mercury (mm Hg) or greater, measured at 20°C (68°F), shall not be used in Source P312.

VII. ADDITIONAL REQUIREMENTS.

009 [25 Pa. Code §127.441]

Operating permit terms and conditions.

Source P312 is a remote reservoir Snap On model YDM132 parts degreaser or cold cleaning machine.

**SECTION D. Source Level Requirements**

Source ID: P313

Source Name: PORTABLE WELDER WITH GASOLINE-FIRED GENERATOR

Source Capacity/Throughput:

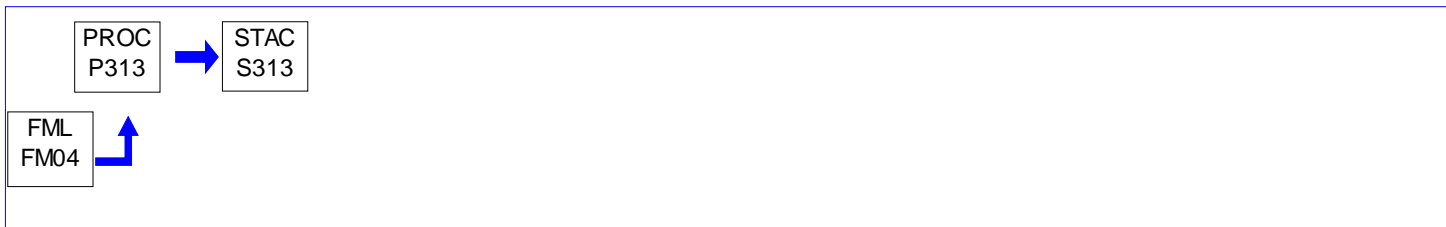
**I. RESTRICTIONS.****Emission Restriction(s).**

001 [25 Pa. Code §123.13]

Processes

The permittee shall not permit the emission of particulate matter into the outdoor atmosphere from Source P313 in such a manner that the concentration of particulate matter in the exhaust exceeds 0.04 grains per dry standard cubic foot of effluent gas volume.

002 [25 Pa. Code §123.21]

General

The permittee shall not permit the emission of sulfur oxides into the outdoor atmosphere from Source P313 in such a manner that the concentration of sulfur oxides, expressed as sulfur dioxide (SO₂), in the exhaust exceeds 500 parts per million, by volume, dry basis.

Fuel Restriction(s).

003 [25 Pa. Code §127.441]

Operating permit terms and conditions.

Source P313 shall only be fired on virgin gasoline.

II. TESTING REQUIREMENTS.

No additional testing requirements exist except as provided in other sections of this permit including Section B (State Only General Requirements).

III. MONITORING REQUIREMENTS.

No additional monitoring requirements exist except as provided in other sections of this permit including Section B (State Only General Requirements).

IV. RECORDKEEPING REQUIREMENTS.

No additional record keeping requirements exist except as provided in other sections of this permit including Section B (State Only General Requirements).

V. REPORTING REQUIREMENTS.

No additional reporting requirements exist except as provided in other sections of this permit including Section B (State Only General Requirements).

**SECTION D. Source Level Requirements****VI. WORK PRACTICE REQUIREMENTS.**

No additional work practice requirements exist except as provided in other sections of this permit including Section B (State Only General Requirements).

VII. ADDITIONAL REQUIREMENTS.

004 [25 Pa. Code §127.441]

Operating permit terms and conditions.

Source P313 is a Miller Bobcat 225 NT portable welder equipped with a 23 horsepower gasoline-fired internal combustion engine.



SECTION E. Source Group Restrictions.



SECTION F. Alternative Operation Requirements.

No Alternative Operations exist for this State Only facility.



SECTION G. Emission Restriction Summary.

No emission restrictions listed in this section of the permit.



SECTION H. Miscellaneous.



***** End of Report *****
